

--	--	--	--	--	--	--	--

Third Semester B.E. Degree Examination
(MECHANICAL)
COMPUTER AIDED MACHINE DRAWING

Time: 3 Hours**Max. Marks: 80**

- Note:** 1. Answer any ONE question from each of the parts A, B and C.
 2. Use **FIRST ANGLE** projection only.
 3. Missing data if any may suitably be assumed.
 4. All the calculations should be on answer sheet supplied.
 5. All the dimensions are in mm.
 6. **Part C Assembled View should be in 3D and other 2 views in 2D.**

PART A

1. A square pyramid of 50mm edges of base and height 70mm rests on its base on HP with one of its base edges parallel to VP. It is cut by an inclined section plane in such a way that the true shape of section is a trapezium whose parallel sides measure 40mm and 20mm. Draw the FV, sectional top view and the true shape of section. **15 Marks**
2. Draw the dimensioned sketches of the following. Indicate the proportions in terms of diameter.
 (a) Flanged nut, (b) Slotted nut **15 Marks**

PART B

3. Draw the sectional Front View and the Top View of a Double Riveted Lap Joint using rivets in Zig Zag arrangements. Thickness of plates = 10 mm. Show all the dimensions on the drawing. **15 Marks**
4. Draw the Sectional Front & Top View of an Oldham's Coupling to connect two shafts of diameter 30mm. **15 Marks**

PART C

5. Details of 'IC ENGINE CONNECTING ROD ' are shown in following Figure 1. Assemble the parts and draw the following views of the assembly.
- i. Sectional Front View
 ii Top View **50 Marks**

6. Figure 2 shows the details of 'SQUARE HEADED TOOLPOST'. Assemble the parts and draw the following views of the assembly.

- i. Half Sectional Front view
- ii. Top view

50 Marks

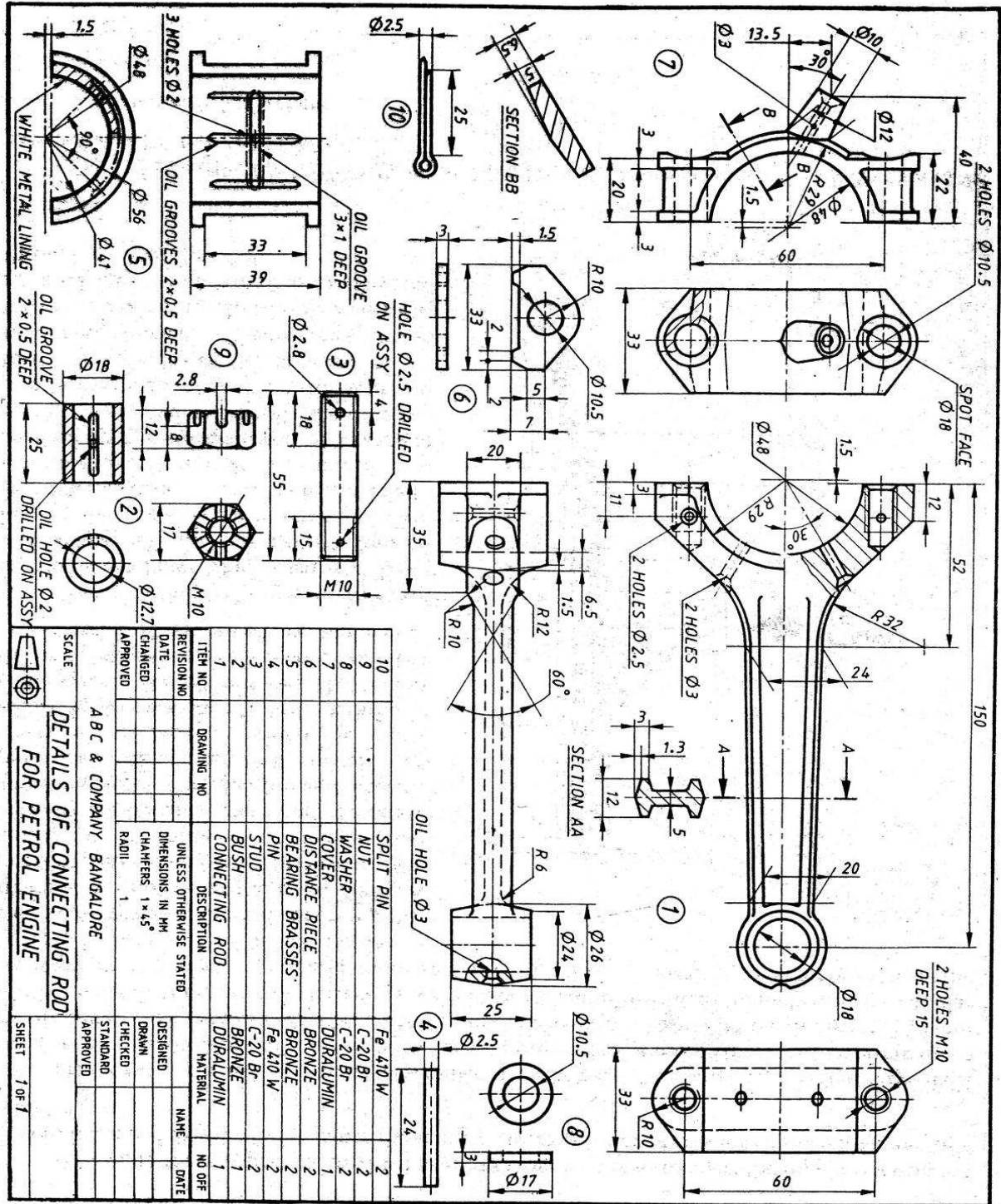
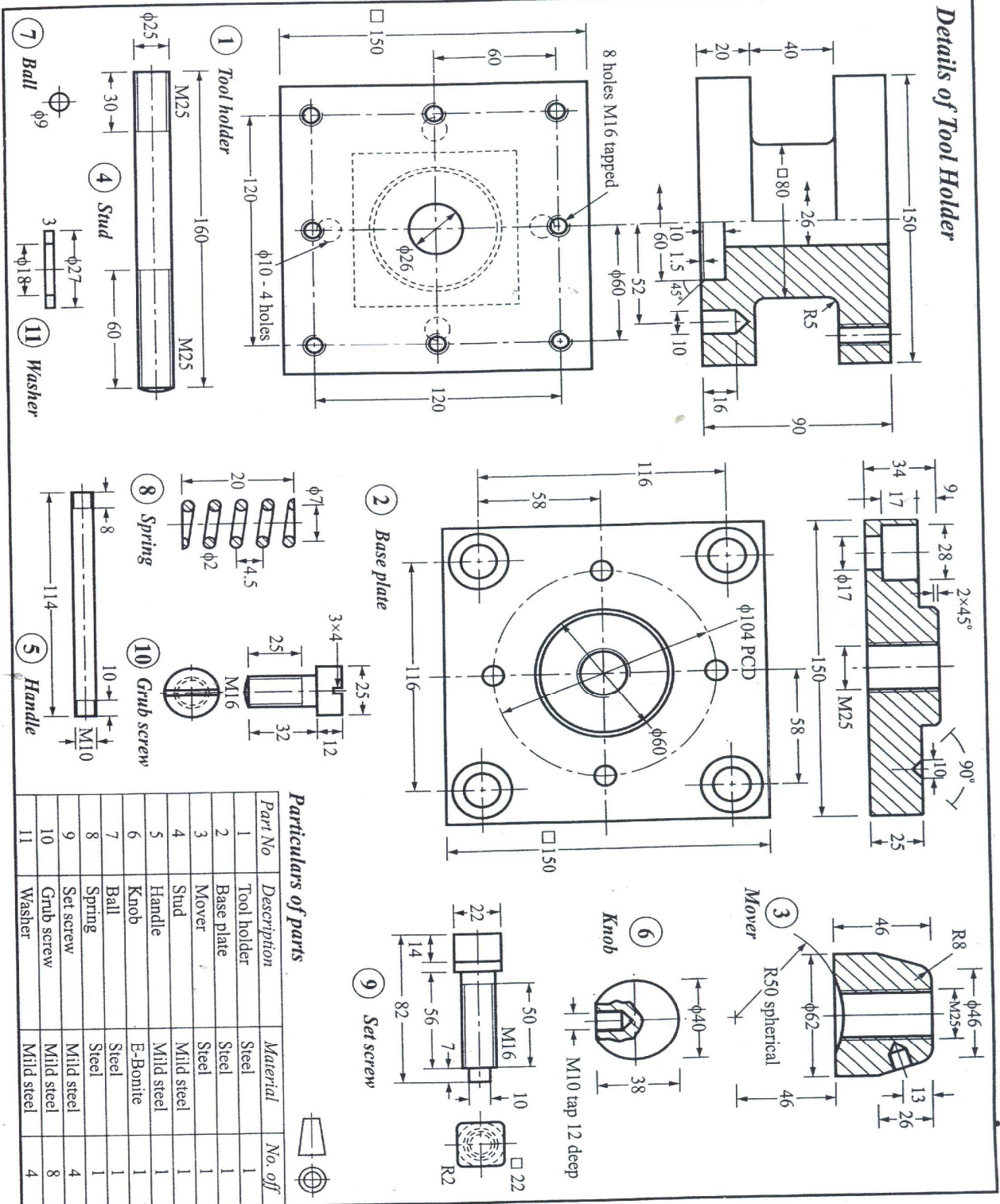

Figure 1 IC ENGINE CONNECTING ROD

Details of Tool Holder



Particulars of parts

Part No	Description	Material	No. off
1	Tool holder	Steel	1
2	Base plate	Steel	1
3	Mover	Steel	1
4	Stud	Mild steel	1
5	Handle	Mild steel	1
6	Knob	E-Bonite	1
7	Ball	Steel	1
8	Spring	Steel	1
9	Set screw	Mild steel	4
10	Grub screw	Mild steel	8
11	Washer	Mild steel	4

Figure 2 'SQUARE HEADED TOOLPOST'