

**VISVESVARAYA TECHNOLOGICAL UNIVERSITY**  
BELAGAVI – 590018



A  
**Project Report Phase II**  
On

**“TO IMPLEMENT 3-PHASE FAULT PROTECTION FOR UNDER-VOLTAGE,  
OVER-VOLTAGE AND OVER-LOAD CONDITIONS USING ARDUINO”**

Submitted in the partial fulfillment of the requirement  
for the VIII Semester Project - 17EEP85 for the award of degree of

**Bachelor of Engineering**  
in  
**Electrical and Electronics Engineering**

By

AISHWARYA M  
(1GV17EE001)

ANUPALLAVI L  
(1GV17EE002)

KEERTHISHREE N  
(1GV17EE007)

MISBA FATHIMA  
(1GV17EE010)

Carried at  
**Dr. T. THIMMAIAH INSTITUTE OF TECHNOLOGY**

Under the Guidance of  
**Mr. Dayananda B R, Asst. Prof,**  
Dept. of EEE, Dr.TTIT, K.G.F.

2020 - 2021



**Dr.T.Thimmaiah Institute of Technology**  
Oorgaum Post, K.G.F-563120  
(Approved by AICTE, New Delhi, Affiliated to VTU-Belagavi,  
Approved by Govt. of Karnataka and ISO 21001-2018 Certified)



**Dr.T.Thimmaiah Institute of Technology**  
Oorgaum Post, K.G.F-563120  
(Approved by AICTE, New Delhi, Affiliated to VTU-Belagavi,  
Approved by Govt. of Karnataka and ISO 21001-2018 Certified)

**DEPARTMENT OF ELECTRICAL AND ELECTRONICS ENGINEERING**

**CERTIFICATE**

Certified that the Project Work entitled

***“TO IMPLEMENT 3-PHASE FAULT PROTECTION FOR UNDER-VOLTAGE, OVER-VOLTAGE AND OVER-LOAD CONDITIONS USING ARDUINO”***

Is a bonafied work carried out by

**AISHWARYA M**

**(1GV17EE001)**

**KEERTHI SHREE N**

**(1GV17EE007)**

**ANUPALLAVI L**

**(1GV17EE002)**

**MISBA FATHIMA**

**(1GV17EE010)**

in the partial fulfillment for the award of degree of Bachelor of Engineering in **Electrical and Electronics Engineering of the Visvesvaraya Technological University**, Belagavi during the year **2020-2021**. It is certified that all corrections/suggestions indicated for the assessment have been incorporated in the report deposited in the departmental library. The Project report has been approved as it satisfies the academic requirement in respect of Project Work-17EEP78 prescribed for the Bachelor of Engineering Degree.

  
.....  
**Signature of Guide**

**Prof. Dayananda B R**

  
.....  
**Signature of HOD**

**Dr. N. Lakshmipathy**

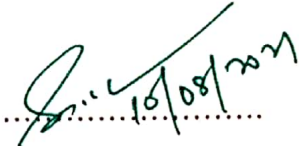
  
.....  
**Signature of Principal**

**Dr. Syed Ariff**

Name of Examiners

1.

2. *Jillian Rufus-J*

3.

Signature with Date

1.

2.  11/8/21

3.

## ABSTRACT

Automation in the distribution field permits utilities on actualizes all the adaptable control for distribution systems, which can be used to upgrade efficiency, reliability, quality of electric service. Automation not only upgrades those qualities but also reduces human effort and saves time. Under, over voltage and over load problem is one of the common types of problems which lead most of the insulation and appliance damage throughout our country. The project aims to develop micro-controller based 3-phase fault protection system. In the event of fault in the 3-phase system the relay trips. The relay closes after resetting it manually. This mechanism will possibly replace the mechanical relays in the system and combine it with data acquisition system which will increase system efficiency and reduce the cost of line equipments. In this paper we are going to show how under, over voltage and over load problem leads a system into catastrophic situation and also describe how those problems can be minimized economically using automation with Arduino based relay system with an alert in IoT system.

**Keywords:** Microcontroller, three phase system, IoT.



GOLDEN VALLEY EDUCATIONAL TRUST

**Dr. T. THIMMAIAH INSTITUTE OF TECHNOLOGY**

Oorgaum, KGF - 563 120.

Affiliated to Visvesvaraya Technological University Belagavi  
Approved By AICTE Govt. of India New Delhi | ISO 21001: 2018 Certified



# *Certificate*

***This is to certify that Miss. Aishwarya M, Student , Dr. T. Thimmaiah Institute of Technology, KGF, presented a paper titled "To Implement 3-Phase Fault Protection For Under-Voltage, Over-Voltage And Over-Load Condition Using Arduino" in the 3rd International Conference on Recent Trends in Technology, Engineering and Applied Science - ICRTTEAS 2021 held virtually on 19th and 20th July 2021.***

Dr. Palaniswamy K M  
Convener

Prof. Ruckmani Divakaran  
General Chair

Dr. H.G. Shenoy  
Vice Principal

Dr. Syed Ariff  
Principal

CertificateID: ICRTTEAS2021/R595



GOLDEN VALLEY EDUCATIONAL TRUST

**Dr. T. THIMMAIAH INSTITUTE OF TECHNOLOGY**

Oorgaum, KGF - 563 120.

Affiliated to Visvesvaraya Technological University Belagavi

Approved By AICTE Govt. of India New Delhi | ISO 21001: 2018 Certified



# *Certificate*

***This is to certify that Miss. Anupallavi L, Student , Dr. T. Thimmaiah Institute of Technology, KGF, presented a paper titled “To Implement 3-Phase Fault Protection For Under-Voltage, Over-Voltage And Over-Load Condition Using Arduino” in the 3rd International Conference on Recent Trends in Technology, Engineering and Applied Science - ICRTTEAS 2021 held virtually on 19th and 20th July 2021.***

Dr. Palaniswamy K M  
Convener

Prof. Ruckmani Divakaran  
General Chair

Dr. H.G. Shenoy  
Vice Principal

Dr. Syed Ariff  
Principal

CertificateID: ICRTTEAS2021/R596



GOLDEN VALLEY EDUCATIONAL TRUST

## Dr. T. THIMMAIAH INSTITUTE OF TECHNOLOGY

Oorgaum, KGF - 563 120.

Affiliated to Visvesvaraya Technological University Belagavi  
Approved By AICTE Govt. of India New Delhi | ISO 21001: 2018 Certified



# Certificate

***This is to certify that Miss. Keerthishree N, Student , Dr. T. Thimmaiah Institute of Technology, KGF, presented a paper titled “To Implement 3-Phase Fault Protection For Under-Voltage, Over-Voltage And Over-Load Condition Using Arduino” in the 3rd International Conference on Recent Trends in Technology, Engineering and Applied Science - ICRTTEAS 2021 held virtually on 19th and 20th July 2021.***

Dr. Palaniswamy K M  
Convener

Prof. Ruckmani Divakaran  
General Chair

Dr. H.G. Shenoy  
Vice Principal

Dr. Syed Ariff  
Principal

**PRINCIPAL**

CertificateID: ICRTTEAS2021/R597

Dr. T. Thimmaiah Institute of Technology  
Oorgaum, KGF - 563 120



GOLDEN VALLEY EDUCATIONAL TRUST  
**Dr. T. THIMMAIAH INSTITUTE OF TECHNOLOGY**  
Oorgaum, KGF - 563 120.

Affiliated to Visvesvaraya Technological University Belagavi  
Approved By AICTE Govt. of India New Delhi | ISO 21001: 2018 Certified



# *Certificate*

***This is to certify that Miss. Misba Fathima , Student , Dr. T. Thimmaiah Institute of Technology, KGF, presented a paper titled “To Implement 3-Phase Fault Protection For Under-Voltage, Over-Voltage And Over-Load Condition Using Arduino” in the 3rd International Conference on Recent Trends in Technology, Engineering and Applied Science - ICRTTEAS 2021 held virtually on 19th and 20th July 2021.***

Dr. Palaniswamy K M  
Convener

Prof. Ruckmani Divakaran  
General Chair

Dr. H.G. Shenoy  
Vice Principal

Dr. Syed Ariff  
Principal

CertificateID: ICRTTEAS2021/R598

# VISVESVARAYA TECHNOLOGICAL UNIVERSITY

BELAGAVI - 590018

2020 -2021



A

**Project Phase Report II**

on

**“A Greener Approach to Harvest Energy Using Piezo-Speed Breaker”**

**Submitted in the partial fulfillment of the requirement  
for the VII Semester Project Phase 2 - 15EEP78 for the award of degree of**

**Bachelor of Engineering**

in

**Electrical and Electronics Engineering**

By

**AJAY SALAUNKE R**

**1GV14EE001**

**ASMA FIRDOUS S**

**1GV15EE004**

**GAGANDEEP R NAIK**

**1GV16EE005**

**MATHEW A M**

**1GV14EE015**

**Carried at**

**Dr. T. THIMMAIAH INSTITUTE OF TECHNOLOGY**

**Under the Guidance of**

**Mr. Ronald Lawrence J, Asst. Prof,**

**Dept. of EEE, Dr. TTIT, K.G.F.**



**Dr. T. Thimmaiah Institute of Technology**

**Oorgaum Post, K.G.F-563120**

**(Approved by AICTE, New Delhi, affiliated to VTU-Belagavi,  
Approved by Govt. of Karnataka and ISO 21001-2018 Certified)**



Dr. T. Thimmaiah Institute of Technology



Oorgaum Post, K.G.F-563120  
(Approved by AICTE, New Delhi, affiliated to VTU-Belagavi,  
Approved by Govt. of Karnataka and ISO 21001-2018 Certified)

DEPARTMENT OF ELECTRICAL AND ELECTRONICS  
ENGINEERING

CERTIFICATE

Certified that the Project Work entitled "A Greener Approach to Harvest Energy Using Piezo-Speed Breaker" is a bonafied work carried out by Ajay Salaunke R-1GV14EE001, Asma Firdous S-1GV15EE004, Gagandeep R Naik-1GV16EE005 and Mathew A M- 1GV14EE015, in the partial fulfillment for the award of degree of Bachelor of Engineering in Electrical and Electronics Engineering of the Visvesvaraya Technological University, Belagavi during the year 2020-2021. It is certified that all corrections/suggestions indicated for the assessment have been incorporated in the report deposited in the departmental library. The Project report has been approved as it satisfies the academic requirement in respect of Project Phase 2-15EEP78 prescribed for the Bachelor of Engineering Degree.

*R Lawrence*  
.....

Signature of Guide  
Mr. Ronald Lawrence J

*MD 6/18/21*  
.....

Signature of HOD  
Dr. N Lakshmi pathy  
**Head of the Department**  
Dept. of Electrical Engineering  
Dr. T. Thimmaiah Institute of Technology  
Oorgaum, K.G.F.-563 120.

Name of Examiners

- 1.
- 2. Jillian Reyes-J

*[Signature]*  
.....  
11/08/2021

Signature of Principal  
Dr. Syed Ariff  
PRINCIPAL  
Dr. T. Thimmaiah Institute of Technology  
Oorgaum, K.G.F. - 563 120.  
Signature with Date

- 1.
- 2. *[Signature]* 11/8/2021

## ABSTRACT

The energy saving, generating, and compensating is the deal of the day. A lot of effort has been spent to generate power from speed breaker and many mechanisms implemented for the same goal. This method of Electrical power generation needs no input power. This Project is implemented by using simple drive mechanism such as Roller, some interfaced Electrical components and chain drive Mechanism. The electro-kinetic power generator is a method of generating electricity by harnessing the kinetic energy of automobiles that drives over the track. In order to overcome this problem, we need to execute the techniques of optimum use of conventional sources for conservation of energy. One such technique is explained here. The count of vehicles passing over speed breakers on roads has increased these days. Such speed breakers are designed for heavy vehicles, as it increases the input torque and ultimately results in increasing the power as output. The main approach of the project is to lighten the street light and to light the villages utilizing the jerking pressure over speed breaker in highways and roadside.

Then, this mechanical energy can be transformed to electrical energy using generator or dynamo which can be stored with the use of a battery. All these conversions take place in an electro-mechanical unit. This energy saved during the daytime can be used at night to light the street lamps. Therefore, by using this arrangement a large amount of energy can be conserved which can be used to fulfil our future demands.



GOLDEN VALLEY EDUCATIONAL TRUST  
**Dr. T. THIMMAIAH INSTITUTE OF TECHNOLOGY**  
Oorgaum, KGF - 563 120.

Affiliated to Visvesvaraya Technological University Belagavi  
Approved By AICTE Govt. of India New Delhi | ISO 21001: 2018 Certified



# *Certificate*

***This is to certify that Mr. Ajay Salaunke.R, Student , Dr. T. Thimmaiah Institute of Technology, KGF, presented a paper titled “A Greener Approach To Harvest Energy Using Piezo Speed Breaker” in the 3rd International Conference on Recent Trends in Technology, Engineering and Applied Science - ICRTTEAS 2021 held virtually on 19th and 20th July 2021.***

Dr. Palaniswamy K M  
Convener

Prof. Ruckmani Divakaran  
General Chair

Dr. H.G. Shenoy  
Vice Principal

Dr. Syed Ariff  
Principal

CertificateID: ICRTTEAS2021/R579



GOLDEN VALLEY EDUCATIONAL TRUST  
**Dr. T. THIMMAIAH INSTITUTE OF TECHNOLOGY**  
Oorgaum, KGF - 563 120.

Affiliated to Visvesvaraya Technological University Belagavi  
Approved By AICTE Govt. of India New Delhi | ISO 21001: 2018 Certified



# *Certificate*

***This is to certify that Miss. Asma Firdous.S, Student , Dr. T. Thimmaiah Institute of Technology, KGF, presented a paper titled "A Greener Approach To Harvest Energy Using Piezo Speed Breaker" in the 3rd International Conference on Recent Trends in Technology, Engineering and Applied Science - ICRTTEAS 2021 held virtually on 19th and 20th July 2021.***

Dr. Palaniswamy K M  
Convener

Prof. Ruckmani Divakaran  
General Chair

Dr. H.G. Shenoy  
Vice Principal

Dr. Syed Ariff  
Principal

CertificateID: ICRTTEAS2021/R580



GOLDEN VALLEY EDUCATIONAL TRUST  
**Dr. T. THIMMAIAH INSTITUTE OF TECHNOLOGY**  
Oorgaum, KGF - 563 120.  
Affiliated to Visvesvaraya Technological University Belagavi  
Approved By AICTE Govt. of India New Delhi | ISO 21001: 2018 Certified



# *Certificate*

***This is to certify that Mr. Gagandeep .R.Naik, Student , Dr. T. Thimmaiah Institute of Technology, KGF, presented a paper titled “A Greener Approach To Harvest Energy Using Piezo Speed Breaker” in the 3rd International Conference on Recent Trends in Technology, Engineering and Applied Science - ICRTTEAS 2021 held virtually on 19th and 20th July 2021.***

Dr. Palaniswamy K M  
Convener

Prof. Ruckmani Divakaran  
General Chair

Dr. H.G. Shenoy  
Vice Principal

Dr. Syed Ariff  
Principal

CertificateID: ICRTTEAS2021/R581



GOLDEN VALLEY EDUCATIONAL TRUST  
**Dr. T. THIMMAIAH INSTITUTE OF TECHNOLOGY**  
Oorgaum, KGF - 563 120.  
Affiliated to Visvesvaraya Technological University Belagavi  
Approved By AICTE Govt. of India New Delhi | ISO 21001: 2018 Certified



# *Certificate*

***This is to certify that Mr. Mathew A M, Student, Dr. T. Thimmaiah Institute of Technology, KGF, presented a paper titled "A Greener Approach To Harvest Energy Using Piezo Speed Breaker" in the 3rd International Conference on Recent Trends in Technology, Engineering and Applied Science - ICRTTEAS 2021 held virtually on 19th and 20th July 2021.***

Dr. Palaniswamy K M  
Convener

Prof. Ruckmani Divakaran  
General Chair

Dr. H.G. Shenoy  
Vice Principal

Dr. Syed Ariff  
Principal

CertificateID: ICRTTEAS2021/R582

VISVESVARAYA TECHNOLOGICAL UNIVERSITY

BELAGAVI – 590018

2020 -2021



A

Project Report Phase I

On

**“Footstep Power Generation Using Piezo Electric Transducers”**

Submitted in the partial fulfillment of the requirement for the 8th semester  
Project Phase 2 -17EEP85 for the award of degree of

**Bachelor of Engineering**

in

**Electrical And Electronics Engineering**

by

**BHAVANI S (1GV17EE003)**

**GIRIJA G (1GV16EE006)**

**SINDHU BM (1GV17EE017)**

Carried out at

**Dr. T. THIMMAIAH INSTITUTE OF TECHNOLOGY**

Under The Guidance of

**Dr.N.Lakshmipathy**

Head of the Department,

Department of Electrical and Electronics Engineering



**Dr. T. Thimmaiah Institute of Technology**

**Oorgaum Post, K.G.F – 563120**

(Approved by AICTE, New Delhi, Affiliated by VTU-  
Belagavi, Approved by Govt. of Karnataka and ISO  
21002018 certified)

**Dr. T. Thimmaiah Institute of Technology**



Oorgaum Post K.G.F – 563120

(Approved by AICTE, New Delhi, Affiliated to VTU – Belagavi,  
Approved by Govt. of Karnataka and ISO 21001 – 2018 certified)

**DEPARTMENT OF ELECTRICAL AND ELECTRONICS ENGINEERING**

## **CERTIFICATE**

Certified that the **Project Work** entitled *“Footstep Power Generation Using Piezo Electric transducer”* is a bonafied work carried out by **Bhavani S – 1GV17EE003**, **Sindhu BM – 1GV17EE017**, and **Girija G – 1GV16EE006** in the partial fulfillment of the requirement for the award of Bachelor of Engineering Degree in Electrical and Electronics during the Year 202-2021. It is certified that all corrections and suggestions indicated assessment has been incorporated in the Report. The Project Report has been approved as it satisfied academic requirements in respect of The Project Work Phase – 2 prescribed for the Degree.

*06/08/21*  
Project Guide and HOD,  
**Dr.N.Lakshmipathy, EEE**

*10/08/2021*  
Principal,  
**Dr.Syed Ariff**





GOLDEN VALLEY EDUCATIONAL TRUST  
**Dr. T. THIMMAIAH INSTITUTE OF TECHNOLOGY**

Oorgaam, KGF - 563 120.

Affiliated to Visvesvaraya Technological University Belagavi  
Approved By AICTE Govt. of India New Delhi | ISO 21001: 2018 Certified

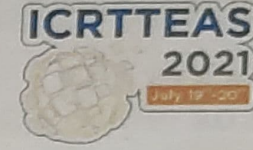

# *Certificate*

***This is to certify that Miss. Bhavani S, Student, Dr. T. Thimmaiah Institute of Technology, KGF, presented a paper titled "Footstep Power Generation Using Piezoelectric Transducer" in the 3rd International Conference on Recent Trends in Technology, Engineering and Applied Science - ICRTTEAS 2021 held virtually on 19th and 20th July 2021.***

Dr. Palaniswamy K M  
Convener

Prof. Ruckmani Divakaran  
General Chair

Dr. H.G. Shenoy  
Vice Principal

Dr. Syed Ariff  
Principal

CertificateID: ICRTTEAS2021/R571

CertificateID:ICRTTEAS2021/P482



GOLDEN VALLEY EDUCATIONAL TRUST

**Dr. T. THIMMAIAH INSTITUTE OF TECHNOLOGY**

Oorgaum, KGF - 563 120.

Affiliated to Visvesvaraya Technological University Belagavi

Approved By AICTE Govt. of India New Delhi | ISO 21001: 2018 Certified



## CERTIFICATE OF PARTICIPATION

This is to certify that

**Mr/Mrs/Ms/Prof. Sindhu B M**

**Dr. T. Thimmaiah Institute of Technology, KGF**

participated in the **3rd International Conference on Recent Trends in Technology, Engineering and Applied Science - ICRTTEAS 2021**, held virtually on 19th and 20th July 2021.

Dr. Palaniswamy K M  
Convener

Prof. Ruckmani Divakaran  
General Chair

Dr. H.G. Shenoy  
Vice Principal

Dr. Syed Ariff  
Principal



GOLDEN VALLEY EDUCATIONAL TRUST

**Dr. T. THIMMAIAH INSTITUTE OF TECHNOLOGY**

Oorgaum, KGF - 563 120.

Affiliated to Visvesvaraya Technological University Belagavi

Approved By AICTE Govt. of India New Delhi | ISO 21001: 2018 Certified



# *Certificate*

***This is to certify that Miss. Girija G, Student, Dr. T. Thimmaiah Institute of Technology, KGF, presented a paper titled "Footstep Power Generation Using Piezoelectric Transducer" in the 3rd International Conference on Recent Trends in Technology, Engineering and Applied Science - ICRTTEAS 2021 held virtually on 19th and 20th July 2021.***

Dr. Palaniswamy K M  
Convener

Prof. Ruckmani Divakaran  
General Chair

Dr. H.G. Shenoy  
Vice Principal

Dr. Syed Ariff  
Principal

CertificateID: ICRTTEAS2021/R570

## ABSTRACT

One of the basic needs of today's life is electric power. A large amount of electric power is needed for various operations, energy demand is increasing linearly day by day along with the increase in population, and this project focuses on the power generation from the increased population without negatively affecting the environment. The footstep walking and running energy is converted into electricity with the help of piezoelectric crystals. It is a non-conventional system in which the mechanical energy from the footsteps is converted into electrical energy. This system can be implemented in many public places. By using Piezo electric crystals, the pressure of the footstep deforms the crystal and produced electrical energy as output.

The footstep power generation, here we proposed is an advanced footstep power generation system that uses the Piezo electric sensors to generate power through footsteps as a source of renewable energy that can be obtained while walking on a certain arrangement like stepping foot on a Piezo tiles, this project describes the use of piezoelectric materials in order to harvest energy from people walking vibration for generating and accumulating the energy.

The basic working principle of footstep power generation system is based on piezoelectric sensors. When the flooring is engineered with piezoelectric technology, the electrical energy produced by the pressure is captured by the flow sensors and converted to an electrical charge by piezoelectric transducer. These sensors are placed in such a way that it generates maximum output voltage. This output is provided to our monitoring circuitry which is microcontroller based circuit that allows user to monitor the voltage and charges a battery, and this power source has many applications. Our project model is cost effective and easy to implement.

A  
**VISVESVARAYA TECHNOLOGICAL UNIVERSITY**  
BELAGAVI - 590018  
2020 -2021



A

**Project Report**  
on

**“DESIGN AND IMPLEMENTATION OF CONTACTLESS HUMAN BODY  
TEMPERATURE & AUTOMATED HAND SANITIZER DISPENSER”**

Submitted in the partial fulfillment of the requirement  
for the VIII Semester Project - 17EEP85 for the award of degree of

**Bachelor of Engineering**  
in  
**Electrical and Electronics Engineering**  
By

<b>FLORENCE V</b>	<b>1GV16EE005</b>
<b>POOJA SHREE B</b>	<b>1GV16EE011</b>
<b>PREETHI SREE M</b>	<b>1GV17EE013</b>
<b>SHAMINI S</b>	<b>1GV17EE015</b>

Carried at  
**Dr.T.THIMMAIAH INSTITUTE OF TECHNOLOGY**

Under the Guidance of  
**Mr.Somashekar B**  
Assoct. Prof.  
Dept. of EEE, Dr.TTIT, K.G.F.



**Dr.T.Thimmaiah Institute of Technology**

Oorgaum Post, K.G.F-563120

(Approved by AICTE, New Delhi, Affiliated to VTU-Belagavi, Approved by Govt. of  
Karnataka and ISO 21001-2018 Certified)

Dr. T. Thimmaiah Institute of Technology



Oorgaum Post, K.G.F-563120  
(Approved by AICTE, New Delhi, Affiliated to VTU- Belagavi,  
Approved by Govt. of Karnataka and ISO 21001-2018 Certified)

DEPARTMENT OF ELECTRICAL AND ELECTRONICS  
ENGINEERING.

CERTIFICATE

Certified that the Project Work entitled "Design and Implementation of Contactless Human body Temperature Measurement and Automated Hand Sanitizer Dispenser" is a bonafied work carried out by FLORENCE V-1GV17EE005, POOJA SHREE B-1GV17EE011, PREETHI SREE M-1GV17EE013, SHAMINI S-1GV17EE015 in the partial fulfillment for the award of degree of Bachelor of Engineering in Electrical and Electronics Engineering of the Visvesvaraya Technological University, Belagavi during the year 2020-2021. It is certified that all corrections/suggestions indicated for the assessment have been incorporated in the report deposited in the departmental library. The Project report has been approved as it satisfies the academic requirement in respect of Project Work- 17EEP85 prescribed for the Bachelor of Engineering Degree.

..... R. L. M. 5/9/2021

Signature of Guide  
Mr. Somashekar B

Name of Examiners

1.

2. Jillian Rufus J

..... Dr. N. Lakshmi Pathy 06/8/21

Signature of HOD  
Dr. N. Lakshmi Pathy

Head of the Department

Dept. of Electrical Engineering  
Dr. T. Thimmaiah Institute of Technology  
Oorgaum, K.G.F.-563 120.

..... 11/08/2021

Signature of Principal  
Dr. T. Thimmaiah Institute of Technology  
Oorgaum, K.G.F. - 563 120.  
Signature with Date

1.

2. 11/8/2021



GOLDEN VALLEY EDUCATIONAL TRUST  
**Dr. T. THIMMAIAH INSTITUTE OF TECHNOLOGY**

Oorgaum, KGF - 563 120.

Affiliated to Visvesvaraya Technological University Belagavi  
Approved By AICTE Govt. of India New Delhi | ISO 21001: 2018 Certified



# *Certificate*

***This is to certify that Miss. Florence V, Student, Dr. T. Thimmaiah Institute of Technology, KGF, presented a paper titled "Design And Implementation Of Contactless Human Body Temperature Measurement And Automated Sanitizer Dispenser" in the 3rd International Conference on Recent Trends in Technology, Engineering and Applied Science - ICRTTEAS 2021 held virtually on 19th and 20th July 2021.***

Dr. Palaniswamy K M  
Convener

Prof. Ruckmanl Divakaran  
General Chair

Dr. H.G. Shenoy  
Vice Principal

Dr. Syed Ariff  
Principal

CertificateID: ICRTTEAS2021/R574



GOLDEN VALLEY EDUCATIONAL TRUST  
**Dr. T. THIMMAIAH INSTITUTE OF TECHNOLOGY**

Oorgaum, KGF - 563 120.

Affiliated to Visvesvaraya Technological University Belagavi  
Approved By AICTE Govt. of India New Delhi | ISO 21001: 2018 Certified



# *Certificate*

**This is to certify that Miss. Pooja Shree B, Student, Dr. T. Thimmaiah Institute of Technology, KGF, presented a paper titled “Design And Implementation Of Contactless Human Body Temperature Measurement And Automated Sanitizer Dispenser” in the 3rd International Conference on Recent Trends in Technology, Engineering and Applied Science - ICRTTEAS 2021 held virtually on 19th and 20th July 2021.**

Dr. Palaniswamy K M  
Convener

Prof. Ruckmani Divakaran  
General Chair

Dr. H.G. Shenoy  
Vice Principal

Dr. Syed Ariff  
Principal

CertificateID: ICRTTEAS2021/R575





GOLDEN VALLEY EDUCATIONAL TRUST

# Dr. T. THIMMAIAH INSTITUTE OF TECHNOLOGY

Oorgaum, KGF - 563 120.

Affiliated to Visvesvaraya Technological University Belagavi

Approved By AICTE Govt. of India New Delhi | ISO 21001: 2018 Certified



## Certificate

***This is to certify that Miss. Preethi Sree M, Student , Dr. T. Thimmaiah Institute of Technology, KGF, presented a paper titled “Design And Implementation Of Contactless Human Body Temperature Measurement And Automated Sanitizer Dispenser” in the 3rd International Conference on Recent Trends in Technology, Engineering and Applied Science - ICRTTEAS 2021 held virtually on 19th and 20th July 2021.***

Dr. Palaniswamy K M  
Convener

Prof. Ruckmani Divakaran  
General Chair

Dr. H.G. Shenoy  
Vice Principal

Dr. Syed Ariff  
Principal

CertificateID: ICRTTEAS2021/R576



GOLDEN VALLEY EDUCATIONAL TRUST  
**Dr. T. THIMMAIAH INSTITUTE OF TECHNOLOGY**  
Oorgaum, KGF - 563 120.

Affiliated to Visvesvaraya Technological University Belagavi  
Approved By AICTE Govt. of India New Delhi | ISO 21001: 2018 Certified



# *Certificate*

***This is to certify that Miss. S Shamini  
, Student, Dr. T. Thimmaiah Institute of Technology, KGF, presented a paper titled “Design And  
Implementation Of Contactless Human Body Temperature Measurement And Automated  
Sanitizer Dispenser” in the 3rd International Conference on Recent Trends in Technology,  
Engineering and Applied Science - ICRTTEAS 2021 held virtually on 19th and 20th July 2021.***

Dr. Palaniswamy K M  
Convener

Prof. Ruckmani Divakaran  
General Chair

Dr. H.G. Shenoy  
Vice Principal

Dr. Syed Ariff  
Principal

CertificateID: ICRTTEAS2021/R577

## ACKNOWLEDGEMENT

It is with the profound feeling of gratitude we would like to express our sincere thanks to our institution **Dr.T.THIMMAIAH INSTITUTE OF TECHNOLOGY, K.G.F** for providing excellent infrastructure for the partial completion of the Project Work.

We wish to express a whole hearted thanks to our president **Dr.T. Venkat Vardan** and Principal **Dr. Syed Ariff** for providing good infrastructure for undertaking this Project Work in college.

Our deep and profound gratitude to **Dr.N Lakshmipathy, Professor and Head of Department of EEE**, for his keen interest and bondless encouragement which we received during the entire period of our project.

We would also like to thank Project Co-Ordinator **Mrs. J Jillian Rufus, Assistant Professor Department of EEE**, for his timely support in the completion of this Project Work.

And also our hearty thanks to our internal guide **Mr. Somashekar B, Associate Professor Department of EEE**, for his useful guidance and encouragement throughout the project development period development period.

We would also like to thank **Project Co-Ordinator Mrs. J Jillian Rufus, Assistant Professor Department of EEE**, for his timely support in the completion of this Project Work.

We would like to thank all teaching and non-teaching staff who was directly and indirectly supported for carrying out this Project Work successfully.

We extend our Hearty thanks to our parents, friends for all the moral support provided during the preparation for the Project Work.

<b>FLOENCE V</b>	<b>(1GV17EE005)</b>
<b>POOJA SHREE B</b>	<b>(1GV17EE011)</b>
<b>PREETHI SREE M</b>	<b>(1GV17EE013)</b>
<b>SHAMINI S</b>	<b>(1GV17EE015)</b>

## **ABSTRACT**

In these critical days of the COVID-19 pandemic, it is difficult to know whether a person is infected with the virus or not. Because the virus will spread from person to person through air medium which results in rapid spreading. During the sanitizing process or checking a person for the infection of the virus an another person i.e. the one who checks , needs to be closer to the one who needs to be checked , at this time the one who checks is in danger to the infection of virus. In order to overcome this situation "Implementation of contactless human temperature sensor and automated sanitizing dispenser" can be used. By using this idea we can use a machine without an human being and reduce the number of affected persons.

As per our idea, here we are using an contactless sensors rather than a contact sensor in order to avoid the contact between the two members. When a person is instructed to stand at the defined place , which is suitable for the sensor to sense. The sensor senses the temperature of the human body and generates the signal and transfers the signal data to the ARDUINO were it converts signal data into an digital data in a suitable way of displaying it on the LCD. After this process the person is allowed to pass if he has normal body temperature ,and sanitized by the automated sanitizer dispenser, If the temperature of the person is more than the normal temperature the buzzer will give an alert sound , and the person is not allowed to pass through .This idea requires both hardware and software components for its working.



<b>CHAPTER 4</b>	<b>IMPLEMENTATION</b>	<b>28</b>
	4.1 Design part	28
	4.1.1 Capacitor	28
	4.1.2 Resistors	28
	4.1.3 Crystal Oscillators	28
	4.2 Hardware Kit	28
	4.2.1 Supply part	29
	4.2.2 Converter part	29
	4.2.3 LCD part	29
	4.2.4 Controller part	30
	4.2.5 Infrared Sensor	30
	4.2.6 Ultrasonic Sensor	30
	4.2.7 Darlington Pair	30
	4.2.8 Relay	30
	4.3 Flow Chart	31
<b>CHAPTER 5</b>	<b>RESULT</b>	<b>33</b>
<b>CHAPTER 6</b>	<b>CONCLUSION &amp; FUTURE SCOPE</b>	<b>36</b>
	6.1 Advantages	36
	6.2 Disadvantage	36
	6.3 Application	36
	6.4 Conclusion	36
	6.5 Future Scope	37
	<b>BIBILOGRAPHY</b>	<b>39</b>

## LIST OF FIGURES

NO	NAMES	PAGE NO
3.1	ATmega2560 Microcontroller	10
3.2	Infrared Thermometer	12
3.3	Ultrasound sensor range	14
3.4	Principle of Ultrasound sensor	15
3.5	Ultrasonic Sensor	16
3.6	LCD	17
3.7	Pin Configuration	18
3.8	Solenoid Water Air Valve	19
3.9	Piezoelectric Buzzer	20
3.10	Typical Schematic of ISD1820	22
3.11	ISD1820	22
3.12	Pin Configuration	23
3.13	Block Diagram of a Regulated Power Supply	24
3.14	Pin Configuration	25
3.15	DC-DC Buck Converter	25
3.16	Battery	26
4.1	Model of the project	29
5.1	Output displayed on LCD	33

**LIST OF TABLE**

3.1	Specification	8
4.1	Specification of the device	28
5.1	Normal body temperature	34
5.2	Human body temperature measurement at different timing	34
5.3	Human body temperature measurement at different condition	35



## Chapter 1

# INTRODUCTION

World is going towards a bad situation due to the Coronavirus disease (COVID-19). Where most of the countries are suffering from this disease as well as everyone is in danger from this unseen virus. Establishments such as businesses, transportation systems, and community pandemic. These plans may include an initial assessment to try to identify people who may be infectious to limit the spread of COVID-19 infections [1].

Temperature measurement can be one part of the assessment to determine if a person has an elevated temperature potentially caused by a COVID-19 infection. One method to measure a person's surface temperature is the use of "no-touch" or non-contact temperature assessment devices, such as thermal imaging systems or non-contact infrared thermometers. The use of other temperature assessment devices, such as oral thermometers, requires physical contact which may increase the risk of spreading infection. The available scientific literature supports using thermal imaging systems and non-contact infrared thermometers to detect elevated temperature [2].

### Benefits of Non-contact Temperature Assessment Devices

- Non-contact devices can quickly measure and display a temperature reading so a large number of people can be evaluated individually at points of entry.
- Non-contact infrared thermometers require minimal cleaning between uses.
- Using non-contact temperature measurement devices may help reduce the risk of spreading COVID-19 infections.

Sanitization means cleaning or sterilizing an object or body part like hands or whole body. Sanitization can be done in many ways including UV Sanitization, Soap Sanitization, Alcohol Sanitization, and Bleach Sanitization and so on. Of the above methods, alcohol was found to be more useful for human beings since it is harmless on skin surface, vaporizes easily and kills most of the viruses, bacteria, and also removes dirt in our hands. Alcohol may be expensive for mass scale sanitization of buildings or rooms and a major disadvantage is that, alcohol is highly inflammable and requires careful storage to avoid catastrophe. Alcohol also makes hands dry since it absorbs moisture, and hence also needs addition of moisturizers. Sanitizers are also provided with antiseptic disinfectants like Chlorohexidine Gluconate. Minimum concentration of alcohol in hand sanitizers must be greater than 70% for effectiveness

against viruses. But, repeatedly touching the hand sanitizer containers to get a drop of sanitizer again initiates contact with persons. Hence there is need for non-contact base hand sanitizer dispenser [3].

Our proposed project does not require any human effort to measure the body temperature or to dispense the hand sanitizer thus by fully making this system automated and a preventive measure in controlling COVID-19

The proposed project can be installed at the Entry point of Hospitals, institutions, factories, industries, shopping Malls, Airports, Railway stations, Bus stands, public places etc., any person getting in is welcomed by an voice message to stand in front of the sensor if the temperature is normal i.e.  $97^{\circ}\text{C}$  to  $99.6^{\circ}\text{C}$  the system prompts the person to place his hand to get the sanitizer and thanks him [4]. If the temperature is above  $100^{\circ}\text{C}$  then the system alerts by turning the buzzer.

The system has HC-SR04 an ultrasonic sensor that senses the presence of the humans, MLX90614 as infrared (IR) contactless thermometer sensor. When compared with the traditional thermometer it shows strong points such as contactless convenient reading, wide range of temperature measurement, and accuracy [5]. MLX90614 is interfaced to Arduino Mega 2560. A 16x2 LCD is used to display the temperature and other information, ISD1820 Voice Recording / Play back IC is used to provide Voice instructions. A Solenoid valve is used to control the flow of sanitizer. The system is dual powered that is it operates on AC mains as well as battery in case of power failure.

## Chapter 2

### LITERATURE SURVEY

**1. Prof. Giselle Ann Alcoran Alvarez, Marc Brain Garcia, Dave Unabia Alvarez, "Automated Social Distancing Gate with Non-Contact Body Temperature Monitoring using Arduino Uno" International Journal of Engineering and Technology (IRJET) July 2020. [1]**

With a total of 74,390 COVID-19 confirmed cases in the Philippines, the country continues to implement tighter precautionary measures especially with the re-opening of business and government establishments in areas under General Community Quarantine. This paper proposes an automatic social distancing gate and body temperature detection sensor that uses infrared, ultrasonic, and infrared thermometer sensors to maximize efficiency and minimize cost. The ultrasonic and infrared sensors are coupled with a speaker to monitor and maintain the social distancing of people entering the gate. An automatic non-contact body temperature is installed at the end of the entrance to check the temperature of individuals before finally entering the vicinity. A buzzer alarms when the detected body temperature is above normal to signal the gate personnel for immediate action. Arduino Uno runs the sensors, speaker and buzzer.

**2. Asif A. Rahimoon, Mohd Noor Abdullah, Ishkrizat Taib "Design of a Contactless Body Temperature Measurement System using Arduino" Indonesian Journal of Electrical Engineering and Computer Science April 17 2020. [2]**

The recent advances in electronics and microelectronics devices allow the development of newly low cost monitoring tools used by peoples for health prevention purposes. Sensor used in medium equipment's convert various forms of human body vital signs into electrical signals. Therefore, the health care monitoring systems considering non-invasive and wearable sensor with integrated communication mediums allow an efficient solution to live a comfortable home life. The paper presents the remote monitoring of human body temperature (HBT) wirelessly by means of Arduino controller with different sensors and open source internet connection. The proposed monitoring system uses an internet network via wireless fieldity (wifi) connection to be linked with online portal on smart phone or computer. The proposed system is comprised of an Arduino controller, LM-35 (S1), MLX-90614 (S2) temperature sensor and ESP-wifi shield

module. The obtained result has shown that real time temperature monitoring data can be transferred to authentic observer by utilizing internet of things (IOT) applications

**3. Marlon Gan Rojo, Jolan Baccay Sy, Eunelfa Regle Callbara , Alan Vincent Comendador, Wubishet Degife , Assefa Sisay, "Non-Contact Temperature Reader with Sanitizer Dispenser (NCTRS D)" , International Journal of Scientific and Research Publications, 2020.[3]**

The design and development of a non-contact temperature reader and sanitizer dispenser (NTRSD) system is presented in this study. The system is intended to help prevent the spread of SARS-CoV-2 Infection and maintaining and/or improving community health and reducing the negative impact of assist in the infection on the economy and society. The NTRSD has two subsystems, the temperature reader (TR) and the sanitizer dispenser (SD), which is controlled from a common microcontroller and by design, cannot operate simultaneously. The TR is designed and developed to perform comparably in terms of accuracy with existing and commercially handheld infrared thermometers, display to the user the temperature read, and give visual and aural alerts when the temperature read exceeds the critical body temperature of 38 degrees centigrade. The SD is designed and developed to deliver sanitizer economically, by dispensing only once and only at a needed amount when activated.

**4. Rakshith L, Dr. K B Shiva kumar, "A Novel Automatic Sanitizer Dispenser" International Journal of Engineering Research and Technology (IJERT), 2020.[4]**

Sanitizing hands are a must to forestall COVID-19. As squeezing the container spout is unhygienic; there is a need for Auto Sanitizer that will guarantee a legitimate cleanliness and well-being in broad daylight spaces which is better solution for industry plants, workplaces, emergency clinics, shopping centers, railroads, shops and homes. Touch-less Completely Programmed sanitizer has been proposed with an inbuilt Ultrasonic sensor (HCSR04) that detects hands when put beneath the gadget and administers the fluid sanitizer. Additionally the proposed unit provides the required amount of spillage and gets prepared for the next action rapidly within 4 seconds of duration.

**5. Juhui Lee, Jin-Young Lee, Sung-Min Cho , Ki-Cheol Yoon, Young Jae Kim , Kwang Gi Kim, "Design of Automatic Hand Sanitizer System Compatible with Various Containers", Healthcare Informatics Research (HIR), 2020.[5]**

Demand for hand sanitizers has surged since the coronavirus broke out and spread around the world. Hand sanitizers are usually applied by squirting the sanitizer liquid when one presses a pump with one's hand. This causes many people to come into contact with the pump handle, which increases the risk of viral transmission. Some hand sanitizers on the market are automatically pumped. However, because sanitizer containers and pump devices are designed to be compatible Only between products produced by the same manufacturer, consumers must also repurchase the container for the liquid if they replace the hand sanitizer. Therefore, this paper suggests the design of an automatic hand sanitizer system compatible with various sanitizer containers. An automatic hand sanitizer system was designed, which will be presented in two stages describing the instrument structure and control parts. This work focused on using the elasticity of pumps and improving people's access to devices. We have designed an automatic hand sanitizer system that is compatible with various containers. When one moves one's hand close to the device sensor, the hand sanitizer container is pumped once. The automatic hand sanitizer device proposed in this paper is ultimately expected to contribute to contactless hand disinfection in public places and virus infection prevention. Additionally, it is economical and eco-friendly by decreasing waste emissions.

**6. Akshay Sharma A S, "Review on Automatic Sanitizer Dispensing Machine" International Journal of Engineering Research and Technology (IJERT), 2020. [6]**

An automatic hand sanitizer dispensing machine is automated, non-contact, alcohol based hand sanitizer dispenser, which finds its use in hospitals, work places, offices, schools and much more. Alcohol is basically a solvent, and also very good disinfectant when compared to liquid soap or solid soap, also it does not need water to wash off since it is volatile and vaporizes instantly after application to hands. It is also proven that a concentration of >70% alcohol can kill Coronavirus in hands. Here, an ultrasonic sensor senses the hand placed near it, the Arduino is used as a microcontroller, which senses the distance and the result is the pump running to pump out the hand sanitizer.

**7. Enerst Edozin, Wantimba Jana, Zaina Kalyankolo, "Design and Implementation of a Smart Hand Sanitizer Dispenser with Door Controller using ATMEGA328P" International Journal of Engineering and Information System (IJEAIS) , 2020.[7]**

In this covid-19 pandemic period which is a global outbreak, hand hygiene is the core preventive measure in the spread of the disease as advised by WHO (World Health Organization) which includes washing hands with water and soap regularly ,hand sanitizing using hand sanitizers, etc. Hygiene refers to the practices conducive to maintaining health and preventing

disease especially through cleanliness such as washing hands, coughing in the elbow etc. Hand washing helps to prevent any diseases that spread through contact. In order to eliminate most of the germs on the hands, one needs to apply a good hand washing practice. In most healthcare settings, alcohol-based hand sanitizers are preferable to hand washing with soap and water because it can be easily tolerated and it is also more effective at reducing bacteria. Hand sanitizer is a liquid, gel, or foam generally used to decrease infectious agents on the hands. A sanitizer is designed to kill germs on skin, objects and surfaces. This research paper aim to design and implement a low cost smart hand sanitizer dispenser with door controller based on ATMEGA328P(Microcontroller), electromagnetic lock and Ultrasonic sensor that can help to solve the challenges faced by security guards at different stations such as bank doors, school gates, hospital gates etc. in enforcing this hand sanitizing action before letting people in to where ever they intend to enter as some people are not willing to collaborate, some look at it as a wastage of their time and also sometimes these security guards can let some people in without sanitizing just because they are their friends or family relatives which is very risky. Therefore, the smart hand sanitizer is stationed at the entrance door and it is connected to the door in such a way that it controls it. That is to say, when a person(s) wants to access the entrance door, they must first sanitizer their hands or else the door will remain locked. With this smart hand sanitizer dispenser, an ultrasonic sensor is used to check the presence of hands below the outlet of the sanitizer machine. It will continuously calculate the distance between the sanitizer outlet and itself and tells the microcontroller to turn on the servo motor whenever the distance is less than 10cm to push the sanitizer out and immediately after the sanitizer outlet dropping some amount into your hands, the electromagnetic lock will de-energize (unlock the door) lighting up a green LED and display a word "The Entrance open the entrance door.

**8. M. M. Srihari, "Self-Activating Sanitizer with Battery Imposed System for Cleansing Hands" IEEE Xplore , 2020.[8]**

This paper gives a brief idea about the automatic hand wash sanitizer. The motor pumps the sanitizer liquid or solution to the human while detecting the IR Sensor. The IR Sensor is the photodiode used for sensing the human hand detection and it is used to control the motor pump from the liquid. The motor is connected to an RC timer delay setup and the pipe connected to a reducer is used to control the flowing liquid of the sanitizer. It has three modes of Control LED's in the system, White LED is used for the user to understand that the setup is in working mode and battery is in use. Red LED is used for the user to understand that Battery is in charging mode, Green LED is used for the user to understand that battery is in full charged mode. It has an on/ off switch to control the whole setup from the battery supply. The consumer

is convenient to use the setup and the user also saves costs and power.

**9. Jing Zhang, "Development of a non-Contact Infrared Thermometer" Advances in Engineering Research (AER), 2017 International Conference advanced Engineering and Technology Research (AETR) 2017. [9]**

Due to the disadvantages of traditional mercury thermometers, such as longer measurement time and necessity of contact with the human body, a thermometer that uses infrared sensors to detect temperature without contact is designed. The Infrared temperature sensor MLX90614 is designed to collect human or object temperature by the SCM to process the temperature into the LCD display and alarm when over temperature. Using software design to complete the control of the system. The smart thermometer can achieve non-contact measurement; place the thermometer in the forehead for a few seconds to get the body temperature, to alarm once the set value is exceeded. The design temperature range is 0-55°C, and temperature resolution is 0.1 °C.

**10. Guangli Long, "Design of a Non-Contact Infrared Thermometer" International Journal on Smart Sensing and Intelligent Systems June 2016. [10]**

In order to realize the human body temperature fast and non-contact measurement, an infrared thermometer is designed. The infrared human body temperature sensor is mainly used to convert the human body's infrared into voltage signal, an operational amplifier to amplify the signal, filter circuit to filter the signal, the analog signal into digital signal by the A/D conversion circuit, data processing by the MCU, LCD display and voice reporting body temperature and time, so the human body non-contact measurement is realized. The experimental results show that: the device can realize the temperature and time of acquisition, the measurement error is not more than 0.5°C, voice broadcast and liquid crystal display the temperature and time, overrun alarm and other functions.

## Chapter 3

# METHODOLOGY

### 3.1 Problem Statement

By using contactless temperature sensor and automated sanitizer dispenser, we are proposing this project for initial assessment to try to identify people who may be infectious to avoid the spread of viruses like COVID-19 infections without employing manpower.

### 3.2 Problem Objective

- ❖ To get accurate result.
- ❖ To design a project to get higher efficiency.
- ❖ To design a touch less hand sanitizer dispenser.

### 3.3 Methodology Adopted

- Sketch IDE (Integrated Development Environment) 1.8.1 or higher version Programming Arduino is used as Software for Programming.
- Hardware module is constructed to measure the temperature of a Human body using digital thermometer contactless MLX90614 Infrared sensor.
- Hardware and Software are embedded.

**Table 3.1: Specifications**

Devices	Operating Voltage	Working Current
Ultrasonic Sensor	5volts	15mA
Infrared Sensor	3.6-5volts	1.5mA
Solenoid Valve	12-24volts	1.25A
Arduino Mege 2560	5volts	50mA



### 3.5 Block Diagram

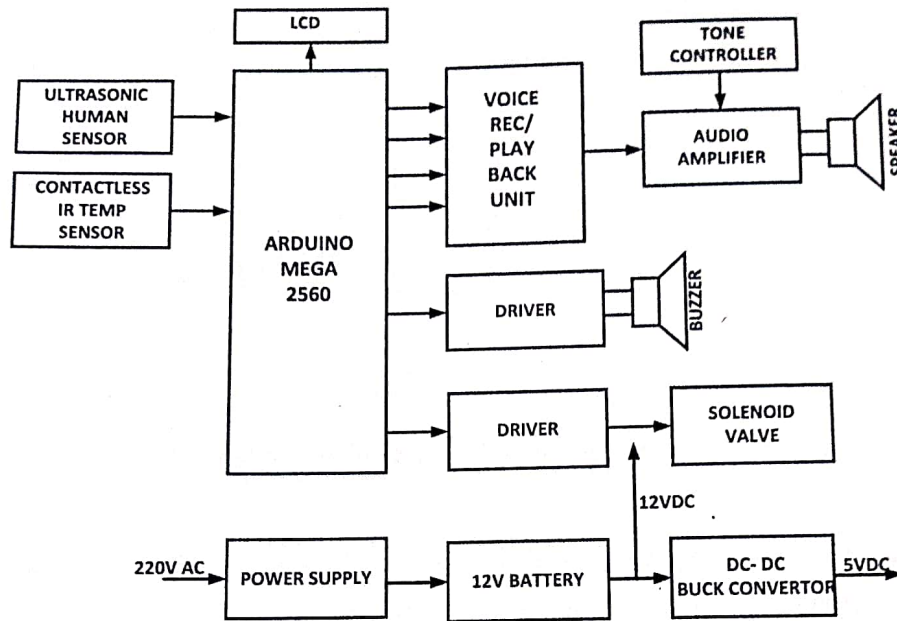

Fig 3.1: Block Diagram

#### 3.5.1 ARDUINO

The Fig.3.1 shown above gives the description about Arduino is a tool for making computers that can sense and control more of the physical world than your desktop computer. It's an open-source physical computing platform based on a simple microcontroller board, and a development environment for writing software for the board.

Arduino can be used to develop interactive objects, taking inputs from a variety of switches or sensors, and controlling a variety of lights, motors, and other physical outputs. Arduino projects can be stand-alone, or they can be communicating with software running on your computer (e.g. Flash, Processing, and Max MSP.) The boards can be assembled by hand or purchased preassembled; the open-source IDE can be downloaded for free. The Arduino programming language is implementation of Wiring, a similar physical computing platform, which is based on the Processing multimedia programming environment.

### ATmega2560 Microcontroller

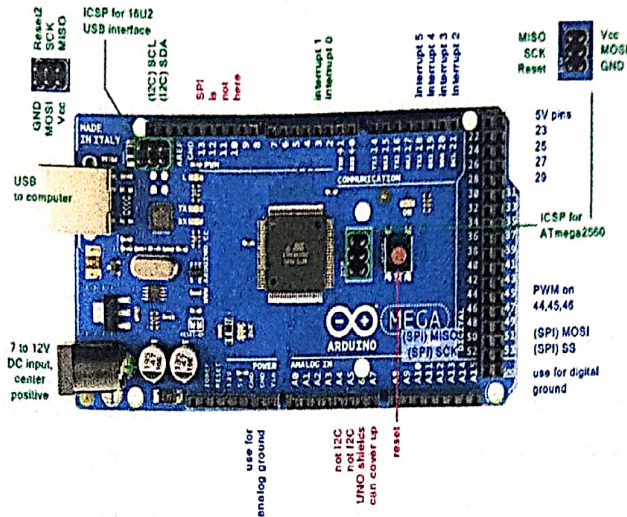

Fig 3.2: ATmega2560 Microcontroller

The ATmega2560 as shown in Fig 3.2 provides the following features: 256K bytes of In-System Programmable Flash with Read-While-Write capabilities, 4Kbytes EEPROM, 8Kbytes SRAM, 54/86 general purpose I/O lines, 32 general purpose working registers, Real Time Counter (RTC), six flexible Timer/Counters with compare modes and PWM, four USARTs, a byte oriented 2-wire Serial Interface, a 16-channel, 10-bit ADC with optional differential input stage with programmable gain, programmable Watchdog Timer with Internal Oscillator, an SPI serial port, IEEE std. 1149.1 compliant JTAG test interface, also used for accessing the On-chip Debug system and programming and six software selectable power saving modes.

The Idle mode stops the CPU while allowing the SRAM, Timer/Counters, SPI port, and interrupt system to continue functioning. The Power-down mode saves the register contents but freezes the Oscillator, disabling all other chip functions until the next interrupt or Hardware Reset. In Power-save mode, the asynchronous timer continues to run, allowing the user to maintain a timer base while the rest of the device is sleeping. The ADC Noise Reduction mode stops the CPU and all I/O modules except Asynchronous Timer and ADC, to minimize switching noise during ADC conversions. In Standby mode, the Crystal/Resonator Oscillator is running while the rest of the device is sleeping. This allows very fast start-up combined with low power consumption. In Extended Standby mode, both the main Oscillator and the Asynchronous Timer continue to run. Atmel offers the Q Touch library for embedding capacitive touch buttons, sliders and wheels functionality into AVR microcontrollers. The

patented charge-transfer signal acquisition offer bust sensing and includes fully debounced reporting of touch keys and includes Adjacent Key Suppression (AKS) technology for unambiguous detection of key events. The easy-to-use QTouch Suite too lchain allows you to explore, develop and debug your own touch applications. The device is manufactured using the Atmel high-density nonvolatile memory technology.

The On-chip ISP Flash allows the program memory to be reprogrammed in-system through an SPI serial interface, by a conventional non-volatile memory programmer, or by an On-chip Boot program running on the AVR core. The boot program can use any interface to download the application program in the application Flash memory. Software in the Boot Flash section will continue to run while the Application Flash section is updated, providing true Read-While-Write operation.

By combining an 8-bit RISC CPU with In-System Self-Programmable Flash on a monolithic chip, the Atmel 2560 is a powerful microcontroller that provides a highly flexible and cost effective solution to many embedded control applications.

#### **Features of ATmega 2560**

- High Performance, Low Power Atmel AVR 8-Bit Microcontroller
- Advanced RISC Architecture
- 135 Powerful Instructions – Most Single Clock Cycle Execution
- 32 × 8 General Purpose Working Register.
- Fully Static Operation
- Up to 16 MIPS Throughput at 16MHz
- On-Chip 2-cycle Multiplier
- High Endurance Non-volatile Memory Segments
- 256KBytes of In-System Self-Programmable Flash
- 4Kbytes EEPROM
- 8Kbytes Internal SRAM
- Write/Erase Cycles:10,000 Flash/100,000 EEPROM
- Data retention: 20 years at 85 °C/ 100 years at 25 °C
- Optional Boot Code Section with Independent Lock Bits
- In-System Programming by On-chip Boot Program
- True Read-While-Write Operation
- Programming Lock for Software Security
- Endurance: Up to 64Kbytes Optional External Memory Space

- Atmel® QTouch® library support
- Capacitive touch buttons, sliders and wheels
- QTouch and QMatrix acquisition
- Up to 64 sense channels
- JTAG (IEEE std. 1149.1 compliant) Interface
- Boundary-scan Capabilities According to the JTAG Standard
- Extensive On-chip Debug Support
- Programming of Flash, EEPROM, Fuses, and Lock Bits through the JTAG **Interface**
- I/O and Packages
- 86 Programmable I/O Lines
- 100-lead TQFP
- ROHS/Fully Green
- Temperature Range:  $-40^{\circ}\text{C}$  to  $85^{\circ}\text{C}$ .

### 3.5.2 MLX90614

The MLX90614 is an Infra-Red thermometer for noncontact temperature measurement as shown in Fig 3.3. Both the IR sensitive thermopile detector chip and the signal conditioning ASSP are integrated in the same TO-39 can. Thanks to its low noise amplifier, 17-bit ADC and powerful DSP unit, a high accuracy and resolution of the thermometer is achieved.

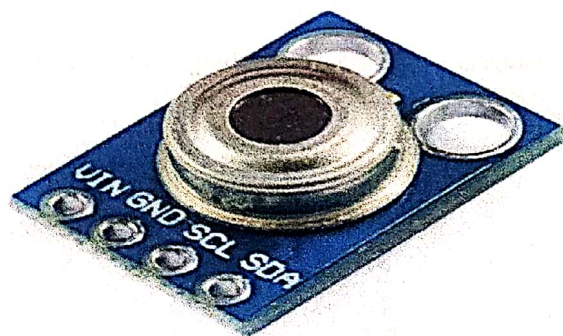

**Fig 3.3: Infrared Thermometer**

The thermometer comes factory calibrated with a digital PWM and SMBus (System Management Bus) output. As a standard, the 10-bit PWM is configured to continuously transmit the measured temperature in range of  $-20$ -  $120^{\circ}\text{C}$ , with an output resolution of  $0.14^{\circ}\text{C}$ . The factory default POR setting is SMBus.

The MLX90614 is factory calibrated in wide temperature ranges:  $-40^{\circ}\text{C}$ - $125^{\circ}\text{C}$  for the ambient temperature and  $-70^{\circ}\text{C}$ - $380^{\circ}\text{C}$  for the object temperature. The measured value is the average temperature of all objects in the Field Of View of the sensor. The MLX90614 offers a standard accuracy of  $\pm 0.5^{\circ}\text{C}$  around room temperatures.

### Features

- Works from 3.3V to 5V input, Module has power regulator IC built in. Standard I2C interface with built 2x pull up resistors
- Operating Voltage: 3V- 5V
- Operating Current: 2mA
- Communication protocol: I2C.
- Sensor working temperature: -40 to +125 Degree C
- Sensing temperature range: -70 to +380 Degree C
- When measuring the temperature, please maintain a measuring distance of 1 cm
- PCB dimensions 11mm x 17 mm
- Easy to integrate
- Factory calibrated in wide temperature range: -40 to 125 °C for sensor temperature and -70 to 380 °C for object temperature.
- High accuracy of  $0.5^{\circ}\text{C}$  over wide temperature range (0-+50 C for both  $T_a$  and  $T_o$ )
- Medical accuracy of  $0.1^{\circ}\text{C}$  in a limited temperature range available on request
- Measurement resolution of  $0.01^{\circ}\text{C}$
- SMBus compatible digital interface for fast temperature readings and building sensor networks
- Customizable PWM output for continuous reading
- Simple adaptation for 8 to 16V applications

### Applications

- High precision non-contact temperature measurements
- Body temperature measurement
- Thermal Comfort sensor for Mobile Air Conditioning control system
- Temperature sensing element for residential, commercial and industrial building air
- Conditioning Wind

- Shield defogging
- Automotive blind angle detection
- Industrial temperature control of moving parts
- Temperature control in printers and copiers
- Home appliances with temperature control
- Healthcare
- Livestock monitoring
- Movement detection
- Multiple zone temperature control – up to 127 sensors can be read via common 2 wires
- Thermal relay / alert.

### 3.5.3 ULTRASOUND

ULTRASOUND is a cyclic sound pressure wave with a frequency greater than the upper limit of the human range as shown in Fig 3.4. Ultrasound is thus not separated from "normal" (audible) sound based on differences in physical properties, only the fact that humans cannot hear it.

Ultrasound is used in many different fields. Ultrasonic devices are used to detect objects and measure distances. Ultrasonic imaging (sonography) is used in human and veterinary medicine. In non-destructive testing of products and structures, ultrasound is used to detect invisible flaws. Industrially, ultrasound is used for cleaning and for mixing, and to accelerate chemical processes. Organisms such as bats and porpoises use ultrasound for locating prey and obstacles.

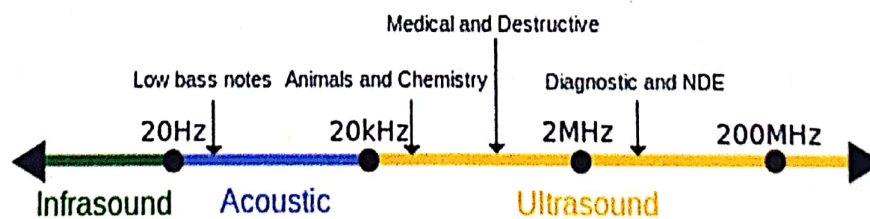

Fig 3.4: Ultrasound sensor range

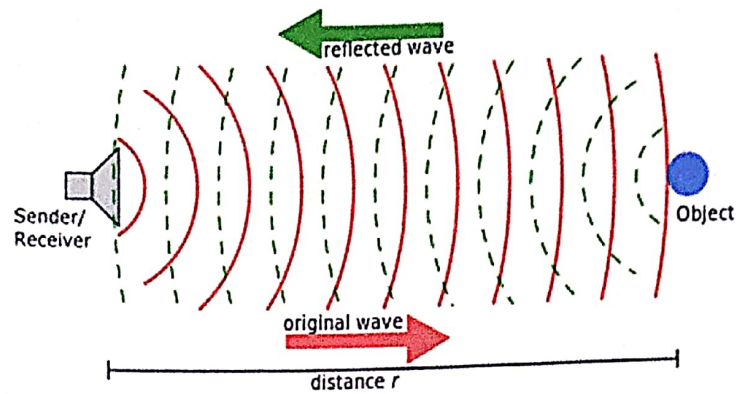

Fig 3.5: Principle of Ultrasound Sensor

### Principle of Active Sonar

A common use of ultrasound is in range finding; this use is also called SONAR, (sound navigation and ranging). An ultrasonic pulse is generated in a particular direction. If there is an object in the path of this pulse, part or all of the pulse will be reflected back to the transmitter as an echo and can be detected through the receiver path as shown in Fig 3.5.

By measuring the difference in time between the pulse being transmitted and the echo being received, it is possible to determine the distance. The measured travel time of SONAR pulses in water is strongly dependent on the temperature and the salinity of the water. Ultrasonic ranging is also applied for measurement in air and for short distances. For example hand-held ultrasonic measuring tools can rapidly measure the layout of rooms.

Although range finding underwater is performed at both sub-audible and audible frequencies for great distances (1 to several kilometers), ultrasonic range finding is used when distances are shorter and the accuracy of the distance measurement is desired to be finer. Ultrasonic measurements may be limited through barrier layers with large salinity, temperature or vortex differentials. Ranging in water varies from about hundreds to thousands of meters, but can be performed with centimeters to meters accuracy

An ultrasonic level or sensing system requires no contact with the target. For many processes in the medical, pharmaceutical, military and general industries this is an advantage over inline sensors that may contaminate the liquids inside a vessel or tube or that may be clogged by the product.

### 3.5.4 HC-SR04

This HC-SR04-Ultrasonic Range Finder is a very popular sensor which is found in many applications where it requires measuring distance and detecting the objects. The module has two eyes like projects in the front which forms the Ultrasonic transmitter and Receiver as shown in Fig 3.6.

The HC-SR04 ultrasonic sensor uses sonar to determine the distance to an object like bats or dolphins do. This Ultrasonic Sensor module is a transmitter, a receiver and a control circuit in one single pack.

The Tigger and the Echo pins are the I/O pins of this module and hence they can be connected to the I/O pins of the microcontroller/Arduino. When the receiver detects return wave the Echo pin goes high for a particular amount of time which will be equal to the time taken for the wave to return back to the sensor. Ultrasonic Ranging Module HC-SR04 provides 2cm-400cm non-contact distance sensing capabilities, Ranging accuracy up to 3mm.

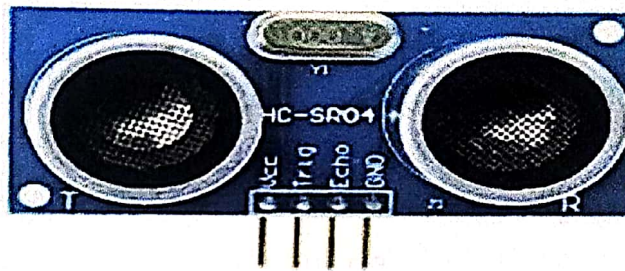

Fig 3.6 : Ultrasonic Sensor

### 3.5.5 LCD

A Liquid Crystal Display (LCD) is a low cost, low-power device capable of displaying text and images as shown in Fig 3.7. LCDs are extremely common in embedded systems, since such systems often do not have video monitors like those that come standard with desktop systems. It can be found in numerous common devices like watches, fax and copy, machines and calculators. LCD Initialization:

The LCD must be initialized before displaying any characters on LCD, the initialization Procedure for LCD driver is:

1. Function set - set 8-bit long data interface.
2. Function set - set 8-bit long data interface.
3. Display on - set display on, cursor on, and blink on.
4. Entry mode set - set entry mode to increment the cursor after a character is displayed.
5. Display Clear - clear the LCD display.



6. Function set - set 8-bit long data interface.
7. Display on - set display on, cursor on, and blink on.
8. Entry mode set - set entry mode to increment the cursor after a character is displayed.
9. Display Clear - clear the LCD display.



**Fig 3.7: LCD**

**LCD pin descriptions:**

**VDD (Pin2), VSS (Pin1):** VDD and VSS provide +5v and ground, respectively.

**VO (Pin3):** VO is used for controlling LCD contrast as shown in Fig 3.8.

**Register Select (RS)(Pin4):**

There are two very important registers inside the LCD. The RS pin is used for as follows. If RS=0, the instruction command register is selected, allowing the user to send a command such as clear display, cursor at home, etc. If RS=1 the data register is selected, allowing the user to send data to be displayed on the LCD.

**Read/Write(R/#W)(Pin5):**

R/#W input allows the user to write information to the LCD or reads information from it. R/W=1 when reading; R/W=0 when writing.

**Enable (E)(Pin6):**

The Enable pin is used by the LCD to latch information presented to its data pins when data is supplied to data pins, a high-to-low pulse must be applied to this pin in order for LCD to latch in the data present at the data pins. This pulse must be a minimum of 450ns wide.

**DO-D7 (Pin 7 to 14):**

The 8-bit Data pins, D0-D7, are used to send information to the LCD or to read the contents of the LCD's internal registers. To display letters and numbers, send ASCII codes of the letters A- Z, a-z, and numbers 0-9 to these pins while RS=1.

**Back Light LED (Pin15, 16):**

LCD has Light Emitting Diode (LED) in the backside to illuminate its panel. Back Light LED

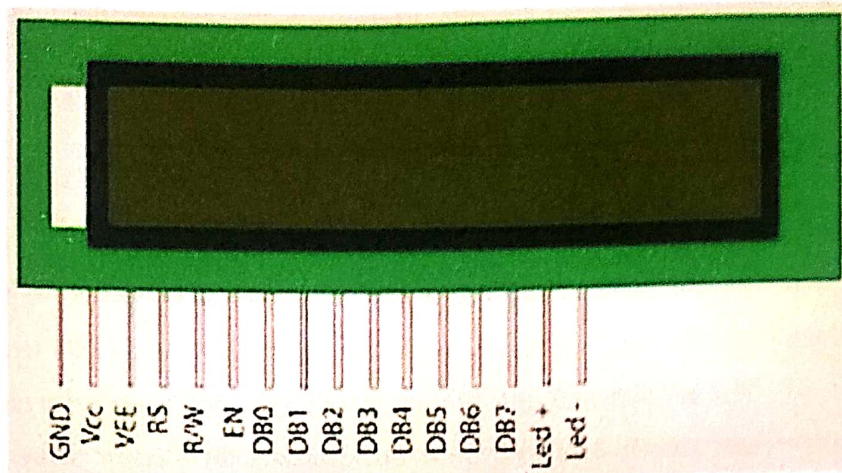

Fig 3.8: Pin Configuration

### 3.5.6 DRIVER

A Darlington pair is two transistors that act as a single transistor but with a much higher current gain. The Darlington Transistor named after its inventor, Sidney Darlington is a special arrangement of two standard NPN or PNP bipolar junction transistors (BJT) connected together. The Emitter of one transistor is connected to the Base of the other to produce a more sensitive transistor with a much larger current gain being useful in applications where current amplification or switching is required. Darlington Transistor pairs can be made from two individually connected bipolar transistors or a one single device commercially made in a single package with the standard: Base, Emitter and Collector connecting leads and are available in a wide variety of case styles and voltage (and current) ratings in both NPN and PNP versions. As we saw in our Transistor as a switch tutorial, as well as being used as an amplifier, the bipolar junction transistor, (BJT) can be made to operate as an ON-OFF switch

When the base of the NPN transistor is grounded (0 volts) and no base current,  $I_b$  flows, no flows from the emitter to the collector and the transistor is therefore switched "OFF". If the base is forward biased by more than 0.7 volts, a current will flow from the emitter to the collector and the transistor is said to be switched "ON". When operated in these two modes, the transistor Operates as a switch.

The problem here is that the transistors Base needs to be switched between zero and some large, positive value for the transistor to become saturated at which point an increased

base current,  $I_b$  flows into the device resulting in collector current  $I_c$  becoming large while  $V_{cc}$  is small. Then we can see that a small current on the base can control a much larger current flowing between the collector and the emitter.

### 3.5.7 SOLENOID WATER AIR VALVE

12V/24V DC Electric Solenoid Water Air Valve Switch (Normally Closed) Controls the flow of fluid or air and act as a valve between high-pressure water and any fluid. There are two 3/4" (Nominal NPT) outlets. Normally, the valve is closed. When 12Vdc is applied to the two terminals, the valve opens and water can push through as shown in Fig 3.9.

The valve works with solenoid coil which operates electronically with DC 12 volt supply. As it is normally closed assembly, it opens the flow of liquid as soon as power ON and stops/blocks the flow when the supply voltage removed.

Suitable for liquid, water, oil, high-end water heaters, intelligent drinking fountains, water heaters, straight drinking machines, water purification machines, steam machines, Energy-saving air-conditioning, water treatment, cooling equipment and water industry and other fields, the use of a large number.

#### Features:

1. Compact and convenient, Easily installed and serviced
2. Precise and reliable. Mechanical no power consumption, Steady flow adjustable.
3. The installation direction can be arbitrary Angle
4. Pressure regulating valve (steady flow valve) function similar to water flow switch

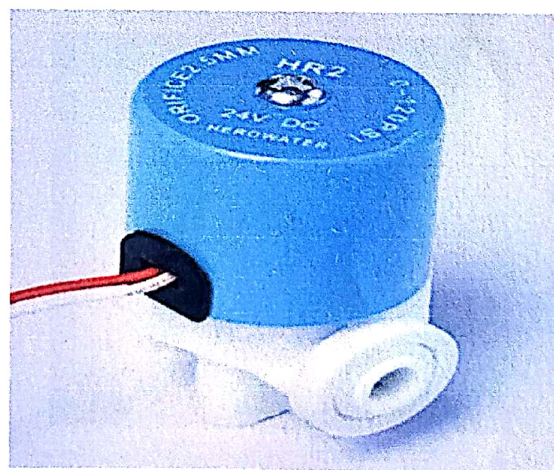

**Fig 3.9: Solenoid Water Air Valve**

### 3.5.8 BUZZER

A buzzer or beeper is an audio signaling device, which may be mechanical, electromechanical, or piezoelectric. Typical uses of buzzers and beepers include alarm devices, timers and confirmation of user input such as a mouse click or keystroke.

#### Types of Buzzers

- **Mechanical**

A joy buzzer is an example of a purely mechanical buzzer.

- **Electromechanical**

Early devices were based on an electromechanical system identical to an electric bell without the metal gong. Similarly, a relay may be connected to interrupt its own actuating current, causing the contacts to buzz. Often these units were anchored to a wall or ceiling to use it as a sounding board. The word "buzzer" comes from the rasping noise that electromechanical buzzers made.

- **Piezoelectric**

A piezoelectric element may be driven by an oscillating electronic circuit or other audio signal source, driven with a piezoelectric audio amplifier. Sounds commonly used to indicate that a button has been pressed are a click, a ring or a beep as shown in Fig 3.10.

The piezo buzzer produces sound based on reverse of the piezoelectric effect. The generation of pressure variation or strain by the application of electric potential across a piezoelectric material is the underlying principle. These buzzers can be used alert a user of an event corresponding to a switching action, counter signal or sensor input.

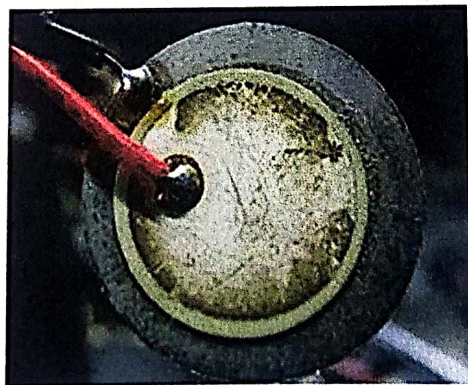

**Fig 3.10 : Piezoelectric Buzzer**

#### Uses of Buzzers

- Electronic metronomes

- Game shows
- Microwave ovens and other household appliances
- Sporting events such as basketball games & Electrical alarms.

### 3.5.9 ISD1820

Voice Record Module is based on ISD1820, which a multiple-message record/playback device. It can offers true single-chip voice recording, no-volatile storage, and playback capability for 8 to 20 seconds. The sample is 3.2k and the total 20s for the Recorder. This module use is very easy which you could direct control by push button on board or by Microcontroller such as Arduino, STM32, Chip Kit etc. Frome these, you can easy control record, playback and repeat and so on.

#### Feature

- Automatic power-down mode
- On-chip 8Ω speaker driver
- Signal 3V to 5V Power Supply
- Can be controlled both manually or by microcontroller
- Sample rate and duration changeable by replacing a single resistor
- Record up to 20 seconds of audio

#### Typical schematic

If you want change record duration, an external resistor is necessary to select the record duration and sampling frequency, which can range from 8 – 20 seconds (4-12k sampling frequency).The Voice Record Module by default is connected to 100k resistor so the default record duration is 10s as shown in Fig 3.11.

- **VCC**– 3.3V power supply
- **GND**– Power ground
- **REC** – The REC input is an active-HIGH record signal. The module starts recording whenever REC is HIGH. This pin must remain HIGH for the duration of the recording as shown in Fig 3.12.
- **PLAYE** – Playback, Edge-activated: When a HIGH-going transition is detected on continues until an End-of-Message (EOM) marker is encountered or the end of the memory space is reached.

- **PLAYL** – Playback, Level-activated, when this input pin level transits for LOW to HIGH, a playback cycle is initiated.

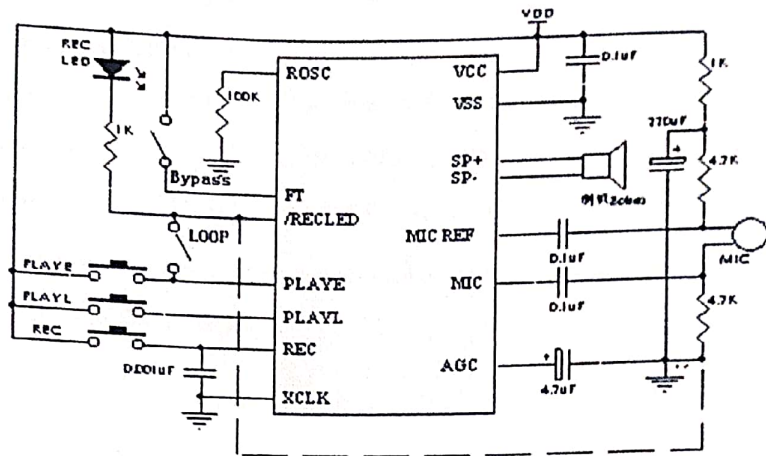

Fig 3.11: Typical Schematic of ISD1820

- **Speaker Outputs** – The SP+ and SP- pins provide direct drive for loudspeakers with impedances as low as 8Ω.
- **MIC** – Microphone Input, the microphone input transfers its signals to the on-chip preamplifier.
- **FT** – Feed Through: This mode enables the Microphone to drive the speaker directly.
- **P-E** – Play the records endlessly.

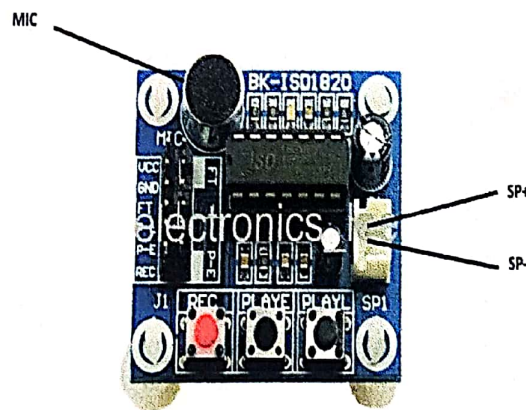

Fig 3.12: ISD1820

### 3.5.10 PAM8403

The PAM8403 is a 3W, class-D audio amplifier. It offers low THD+N, allowing it to achieve high-quality sound reproduction. The new filter less architecture allows the device to drive the speaker directly, requiring no low-pass output filters, thus saving system cost and PCB area. With the same numbers of external components, the efficiency of the PAM8403 is much better than that of Class-AB cousins as shown in Fig 3.13.

It can extend the battery life, which makes it well-suited for portable applications. The PAM8403 is available in SOP-16 package

#### Features

- 3W Output at 10% THD with a 4Ω Load and 5V Power Supply
- Filter less, Low Quiescent Current and Low EMI
- Superior Low Noise
- Short Circuit Protection
- Thermal Shutdown
- Few External Components to Save the Space and Cost
- Efficiency up to 90%

#### Pin out

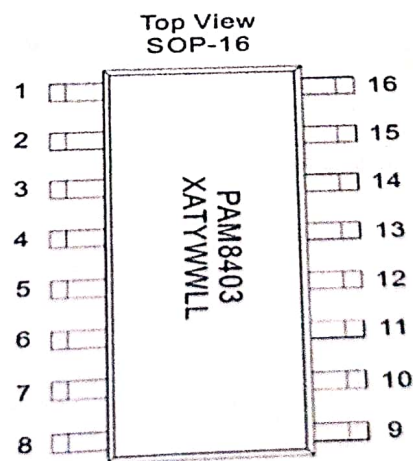

Fig 3.13 : Pin configuration

### 3.5.11 Power supply

A power supply is a device that supplies electrical energy to one or more electric loads. The term is most commonly applied to devices that convert one form of electrical energy to another, though it may also refer to devices that convert another form of energy (e.g., mechanical, chemical, solar) to electrical energy. A regulated power supply is one that controls the output voltage or current to a specific value; the controlled value is held nearly constant despite variations in either load current or the voltage supplied by the power supply's energy source as shown in Fig 3.14.

An AC powered unregulated power supply usually uses a transformer to convert the voltage from the wall outlet (mains) to a different, nowadays usually lower, voltage. If it is used to produce DC, a rectifier is used to convert alternating voltage to a pulsating direct voltage, followed by a filter, comprising one or more capacitors, resistors, and sometimes inductors, to filter out (smooth) most of the pulsation transformer-steps down high voltage AC mains to low voltage AC.

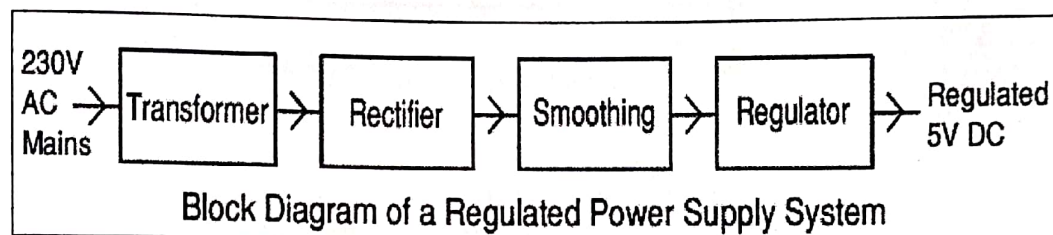

Fig 3.14: Block Diagram of Regulation Power Supply

- Rectifier-converts AC to DC, but the DC output is varying.
- Smoothing-smoothes the DC from varying greatly to a small ripple.
- Regulator-eliminates ripple by setting DC output to a fixed voltage.

### 3.5.12 LM2596

DC-DC Buck Converter Step down Module LM2596 Power Supply is a step-down (buck) switching regulator, capable of driving a 3-A load with excellent line and load regulation. These devices are available in fixed output voltages of 3.3 V, 5 V, 12 V, and an adjustable output version. The LM2596 series operates at a switching frequency of 150 kHz, thus allowing smaller sized filter components than what would be required with lower frequency switching regulators as shown in Fig 3.15.



**Specifications of DC-DC Buck Converter Step Down Module LM2596 Power Supply:**

- Conversion efficiency: 92%(highest)
- Switching frequency: 150KHz
- Load Regulation:  $\pm 0.5\%$
- Voltage Regulation:  $\pm 0.5\%$
- Dynamic Response speed: 5% 200uS
- Input voltage: 4.75-35V
- Output voltage: 1.25-26V(Adjustable)
- Output current: Rated current is 2A, maximum 3A(Additional heat sink is required)
- Conversion Efficiency: Up to 92% (output voltage higher, the higher the efficiency)

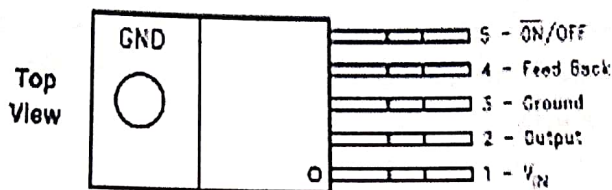

**Fig 3.15: Pin Configuration**

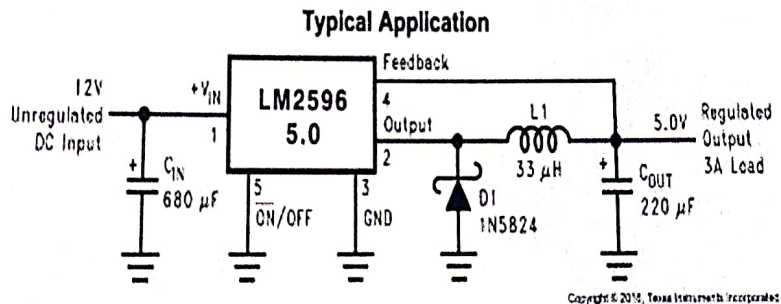

**Fig: 3.16: DC-DC Buck Converter**

**3.5.13 BATTERY**

The lead–acid battery was invented in 1859 by French physicist Gaston Plant and is the oldest type of rechargeable battery. Despite having a very low energy-to-weight ratio and a low energy- to-volume ratio, its ability to supply high surge currents means that the cells have a relatively large power-to-weight ratio. This feature, along with their low cost, makes it attractive for use in motor vehicles to provide the high current required by automobile starter

motors.

As they are inexpensive compared to newer technologies, lead-acid batteries are widely used even when surge current is not important and other designs could provide higher energy densities. Large-format lead-acid designs are widely used for storage in backup power supplies in cell phone towers, high-availability settings like hospitals, and stand-alone power systems. For these roles, modified versions of maintenance requirements. Gel-cells and absorbed glass-mat batteries are common in these roles, collectively known as VRLA (valve-regulated lead-acid) batteries.

Lead-acid battery sales account for 40–45% of the value from batteries sold worldwide. Automotive battery recycling

Lead-acid battery recycling is one of the most successful recycling programs in the world. In the United States 99% of all battery lead was recycled between 2009 and 2013. An effective pollution control system is a necessity to prevent lead emission. Continuous improvement in battery recycling plants and furnace designs is required to keep pace with emission standards for lead smelters as shown in Fig 3.17.



Fig 3.17: Battery

### 3.5.14 SKETCH H

The Sketch IDE (Integrated Development Environment) is a special program running on your computer that allows you to write sketches for the Arduino board in a simple language modelled after the Processing language. The magic happens when you press the button that uploads the sketch to the board: the code that you have written is translated into the C language, and is passed to the AVR-GCC compiler, an important piece of open source software that makes. Final translation into the language understood by the microcontroller.

This last step is quite important, because it's where Arduino makes your life simple by hiding away as much as possible of the complexities of programming microcontrollers.

The programming cycle on Arduino is basically as follows:

- Plug your board into a USB port on your computer.
- Write a sketch that will bring the board to life.
- Upload this sketch to the board through the USB connection and wait a Couple of Seconds for the board to restart.
- The board executes the sketch that you wrote.

The idea of sketching in code is a way of thinking about writing code as a simple intuitive process, just like drawing in a sketchbook. In this way, an Arduino program is called a sketch and is saved in a folder called a sketchbook. Sketching means we can get our hands dirty and quickly try out a new idea. It is a skill available to all of us.

## Chapter 4

### IMPLEMENTATION

#### 4.1 DESIGN PART:

**Table 4.1: Specifications of the devices**

Sl.No	Device	Voltage Rating		Current Rating
1.	Ultrasonic sensors	5V		15mA
2.	MLX906154	5V		1.5mA
3.	Transformer	1 <sup>o</sup> -220V	2 <sup>o</sup> - 12V	1A
4.	LCD	5V		-
5.	AVR ATmega 2560	5V		50mA
6.	Tip 122	5V		100mA
7.	DC547	5V		2A
8.	Buzzer	12V		100mA
9.	Solenoid Valve	12V		1A

##### 4.1.1 CAPACITORS:

Capacitors are used to filter the noise and to remove the harmonics

- Capacitors used in converter part = 1500 $\mu$ f

##### 4.1.2 RESISTORS:

- Resistor used in LCD = 1 $\Omega$ K
- Resistor used in MLX90614 = Two 4.7 k $\Omega$
- Resistor used in voltage divider = 4.7k $\Omega$  and 2.2k $\Omega$

**4.1.3 CRYSTAL OSCILLATORS:** Used to provide the clock pulse for the microcontroller.  
The clock pulse is of 16MHz

## 4.2 Hardware Kit

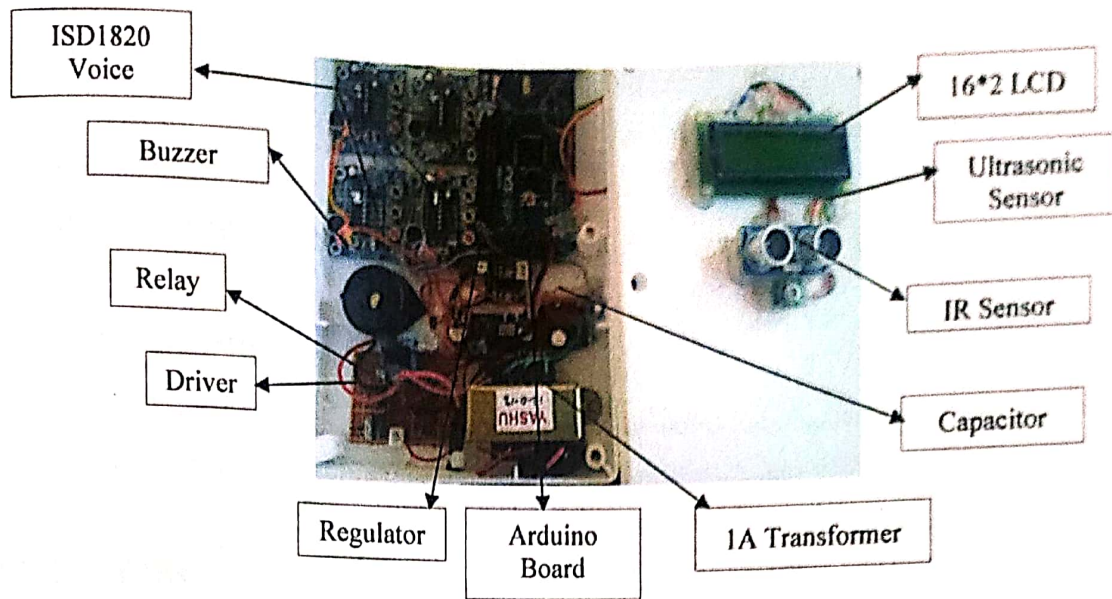

Fig 4.1: Model of the project

### 4.2.1 SUPPLY PART:

- ❖ 5V – LCD, Microcontroller, Ultrasonic sensors, Infrared sensor, ISD1820, Amplifier.
- ❖ 12V – Driver, Relay, Buzzer, Solenoid Valve.

### 4.2.2 CONVERTER PART:

We require a voltage regulator, two diode for rectification, capacitor to remove the noise, AMS1117.

- ❖ Voltage regulator converts 12V to 5V.

### 4.2.3 LCD Part:

A Liquid Crystal Display (LCD) is a low cost, low-power device capable of displaying text and images. LCDs are extremely common in embedded systems, since such systems often do not have video monitors like those that come standard with desktop systems. It can be found in numerous common devices like watches, fax and copy, machines and calculators.

- ❖ D4, D5, D6, D7 are the data pins used.
- ❖ Rs and Rw are the control pins used.

### 4.2.4 CONTROLLER PART:

AVR AT mega 2560 is an 8 bit microcontroller with inbuilt ADC.

- ❖ It executes powerful instructions in a single clock cycle.

- ❖ Crystal oscillators are used to remove the noise.

#### **4.2.5 INFRARED SENSOR:**

5V and 1.5mA Contactless Sensor is used detect the temperature of the object and works on principle of Steph's Boltzmann law. It has two feature inbuilt in it which is used to convert the light energy to appropriate temperature.

#### **4.2.6 ULTRASONIC SENSOR:**

5V and 15mA Ultrasonic sensor is used are used to detect the objects greater then upper limit of human hearing i.e., approximating 20 kHz to 40 kHz.

#### **4.2.7 DARLINGTON PAIR:**

In some application the amount of input current available to switch on a transistor is very low. This may mean that a single transistor may not be able to pass sufficient current required by the load.

#### **4.2.8 RELAY:**

12V and 30 ampere electromechanical relay is used. The term relay generally refers to a device that provides an electrical connection between two or more points in response to the application of a control signal. The most common and widely used type of electrical relay is the electromechanical relay or EMR.

4.3 FLOW CHART:

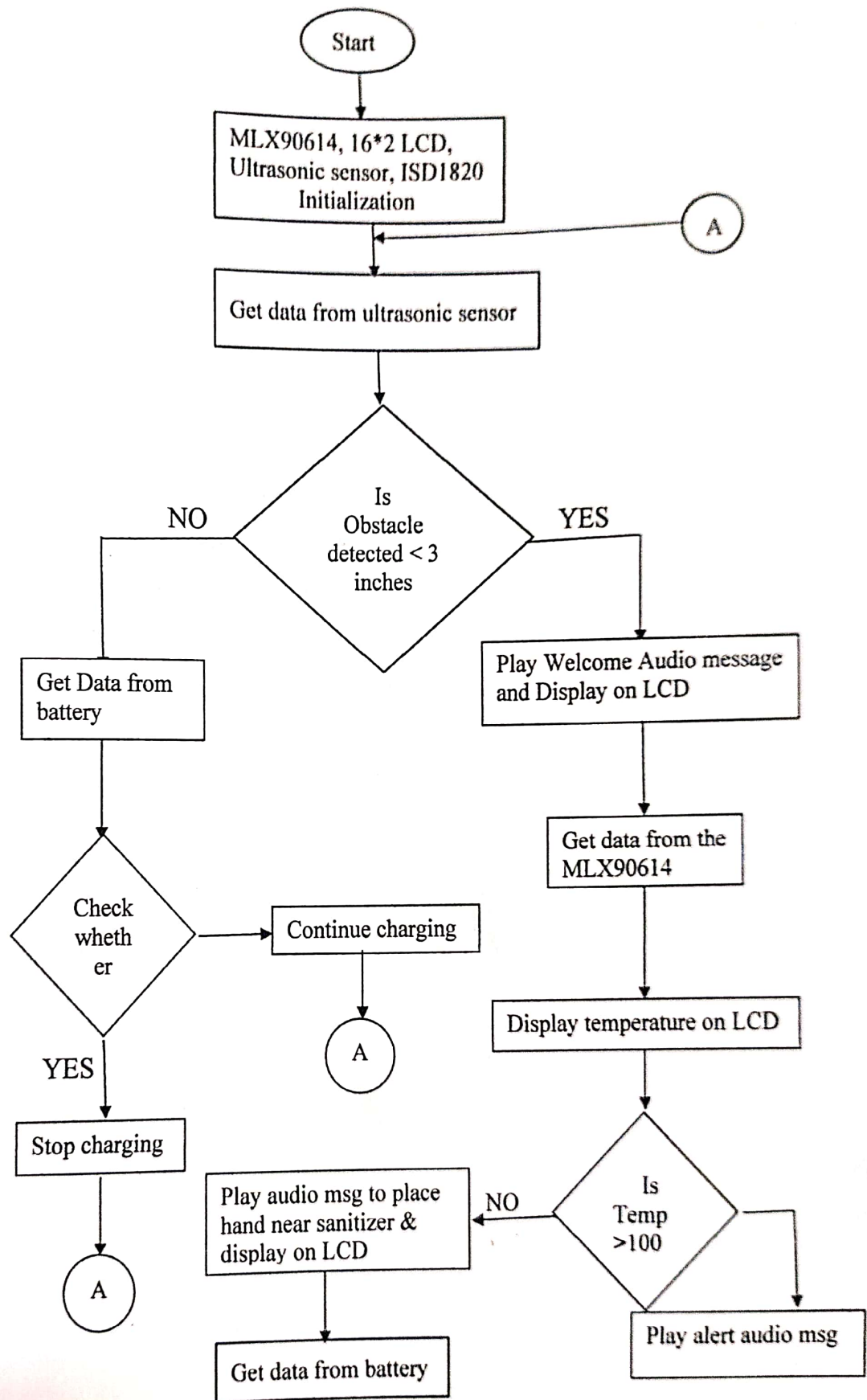

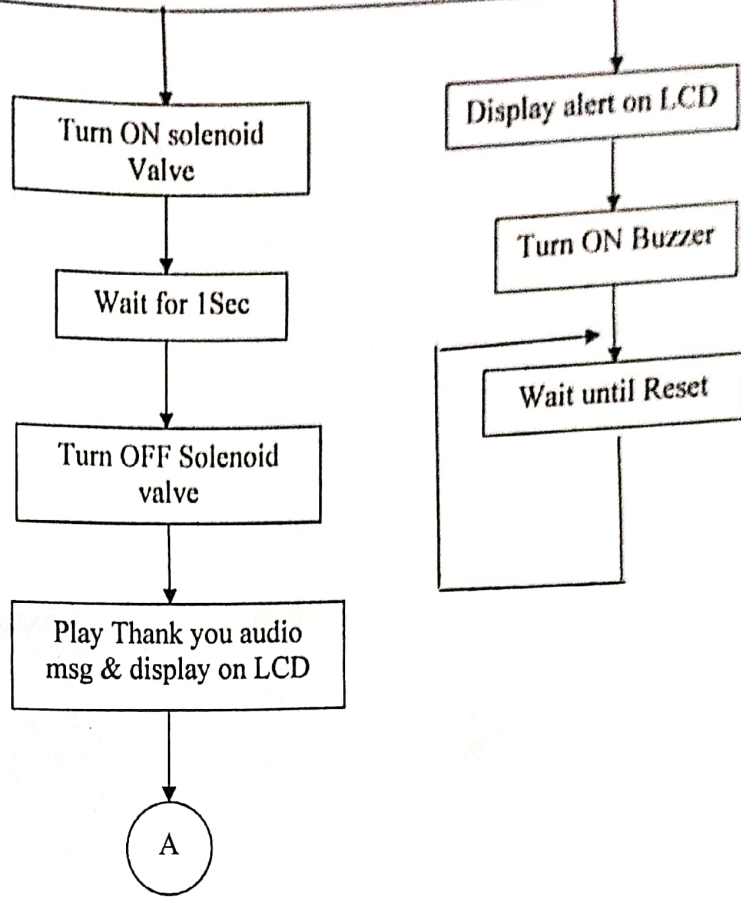



## Chapter 5

### RESULTS

As per the proposed project, we have successfully Implemented, Automatic Contactless Body Temperature Measuring and Sanitizer Dispensing System. The body temperature measured by our system was cross verified by an IR temperature measuring device and found to be accurate with only +0.2% of error. The output displayed on the LCD is as shown in the fig 5.1.



Fig 5.1: Output Displayed On LCD

Table 5.1: Normal body temperature

SL.NO	Time Interval	Time taken to measure temperature for a person	Temperature of human body	Output of Voice record
01	4.20 sec	12.62 sec	32.9 <sup>0</sup> C, 91.2 <sup>0</sup> F	Welcome, Place your hand for sanitizer, thank you
02	4.34 sec	12.42 sec	30.9 <sup>0</sup> C , 87.6 <sup>0</sup> F	Welcome, Place your hand for sanitizer, thank you
03	4.42 sec	11.58 sec	29.5 <sup>0</sup> C, 85 <sup>0</sup> F	Welcome, Place your hand for sanitizer, thank you
04	4.58 sec	12.34 sec	19.7 <sup>0</sup> C, 67.46 <sup>0</sup> F	Welcome, Place your hand for sanitizer, thank you

Table 5.2: Human Body Temperature Measurement at Different timing.

SL.NO	Time Interval	Temperature of human body	Output of Voice record
01	6am	30.9 <sup>0</sup> C , 87.6 <sup>0</sup> F	Welcome, Place your hand for sanitizer, thank you
02	9am	31.7 <sup>0</sup> C, 89 <sup>0</sup> F	Welcome, Place your hand for sanitizer, thank you
03	12am	33.1 <sup>0</sup> C, 91.6 <sup>0</sup> F	Welcome, Place your hand for sanitizer, thank you
04	3pm	32.9 <sup>0</sup> C, 91.2 <sup>0</sup> F	Welcome, Place your hand for sanitizer, thank you
05	6pm	30.4 <sup>0</sup> C, 86.8 <sup>0</sup> F	Welcome, Place your hand for sanitizer, thank you
06	9pm	29.5 <sup>0</sup> C, 85 <sup>0</sup> F	Welcome, Place your hand for sanitizer, thank you

Table 5.3: Human Body Temperature Measurement at different conditions.

SL.NO	Weather Condition	Timings	Temperature of human body	Output of Voice record
01	Cold	3:45 am	19.7 <sup>0</sup> C, 67.46 <sup>0</sup> F	Welcome, Place your hand for sanitizer, thank you
02	Normal	9:00am	30.1 <sup>0</sup> C, 86.2 <sup>0</sup> F	Welcome, Place your hand for sanitizer, thank you
03	Hot	1:00pm	38.5 <sup>0</sup> C, 101.3 <sup>0</sup> F	High body temperature should not allow in.



## Chapter 6

# CONCLUSION AND FUTURE SCOPE

### 6.1 ADVANTAGES

- Non-contact devices can quickly measure and display a temperature reading so a large number of people can be evaluated individually at points of entry.
- Non-contact infrared thermometers require minimal cleaning between uses.
- Alerts on High Temperature.

### 6.2 DISADVANTAGES

- It requires an external source (Battery) when power failure occurs.
- Viruses cannot be identified.

### 6.3 APPLICATIONS

- Residential.
- Commercial.
- Industrial.

### 6.4 CONCLUSION

In this paper, the Contactless Human Body Temperature Measurement and Automated Sanitizer Dispenser system is designed and implemented. The measured temperature is displayed through the LCD, if the temperature is normal i.e., 97<sup>0</sup>F to 99.6<sup>0</sup>F the system prompts the person to sanitize his hand. If the temperature is above 100<sup>0</sup> F then the system alerts by turning the buzzer. Our project does not require any human effort to measure the body temperature or to dispense the hand sanitizer thus by fully making this system automated and a preventive measure in controlling COVID-19 virus and other illness.

## **6.5 FUTURE SCOPE**

This is a portable model which is used to safe guard the motor under various parameters using to IOT technology. Due to day by day increase in the technology by using the same model we can also implement the following in the software part.

- Using IOT technology the temperature detected will be notified to the customer anywhere in the world.
- GSM Technology temperature detected will be notified.

## Software Coding for Arduino to Measure Temperature & Automatic Hand Sanitizer Dispenser.

```
#include <Wire.h>

#include <Adafruit_MLX90614.h>
Adafruit_MLX90614 mlx = Adafruit_MLX90614 ();
Float temperature;
Const float threshold=37.8; //==100F
#include <LiquidCrystal.h>
Liquid Crystal lcd (2, 3, 4, 5, 6, 7);
Byte batt [8] =
{
B01110,
B11111,
B11111,
B11111,
B11111,
B11111,
B11111,
B11111,
};
#define echo 8
#define trig 9
Int distance;
Long duration;
#define battery A15
#define dc_in A14
```



```
Float t_charge, tbattery;  
  
Long bat;  
  
Int percent;  
  
#define msg1 22  
  
#define msg2 24  
  
#define msg3 26  
  
#define msg4 28  
  
Float sani_timer = 1.5;    // 1 for 1sec  
  
#define buzzer    32  
  
#define valve    34  
  
#define charge_cut 30  
  
Void setup ()  
  
{  
  
  lcd.Begin (16, 2);  
  
  lcd.createChar (0, batt);  
  
  mlx.begin ();  
  
  lcd.clear ();  
  
  lcd.print ("SENSORS");  
  
  lcd.setCursor (0, 1);  
  
  lcd.print ("INTAILIZING.....");  
  
  delay (3000);  
  
  Pin Mode (echo, INPUT);  
  
  Pin Mode (trig, OUTPUT);  
  
  Pin Mode (buzzer, OUTPUT);  
  
  Pin Mode (valve, OUTPUT);  
  
  Pin Mode (msg1, OUTPUT);  
  
  Pin Mode (msg2, OUTPUT);
```

```
Pin Mode (msg3, OUTPUT);
Pin Mode (msg4, OUTPUT);
digitalWrite (msg1, LOW);
digitalWrite(msg2, LOW);
digitalWrite(msg3,LOW);
digitalWrite(msg4,LOW);
PinMode (charge_cut, OUTPUT);
lcd.clear ();
lcd.print ("AUTO TEMP &");
lcd.setCursor (0, 1);
lcd.print ("SANITIZER SYS");
delay (2000);
}
Void loop ()
{
delay (100);

//////////////////////////////////// AC //////////////////////////////////////

t_charge = analog Read (dc_in);
t_charge = t_charge / (1024.0/5.0);
t_charge = t_charge*24.15;

//////////////////////////////////// BATT //////////////////////////////////////

bat=0;

for (int i=0; i<100; i++)
{
tbattery = analog Read (battery);

bat = tbattery+bat;

delay (1);
```



```
}  
bat=bat/100;  
tbattery = bat /(1024.0/5.0);  
tbattery = tbattery*23.5;  
Percent = (tbattery*100)/13.0;  
If (percent > 100)  
Percent = 100;  
lcd.clear ();  
lcd.print (" W E L C O M E");  
lcd.setCursor (0, 1);  
lcd. Write (byte (0));  
lcd.print (percent);  
lcd.print ("% "); lcd.print (tbattery, 1);  
lcd.print ("V");  
////////////////////Charge cutoff////////////////////  
if (tbattery > 13.5)  
{  
digitalWrite (charge_cut, HIGH);  
lcd.setCursor (11, 1);  
lcd.print (" ");  
lcd.setCursor (11, 1);  
lcd.print (" FULL");  
}  
else  
{  
if (t_charge > 12)  
{
```

```
digitalWrite (charge_cut, LOW);  
  
lcd.setCursor (11, 1);  
  
lcd.print ("    ");  
  
lcd.setCursor (11, 1);  
  
lcd.print ("CH >>");  
  
}  
  
else  
  
{  
  
digitalWrite(charge_cut, LOW);  
  
lcd.setCursor (11, 1);  
  
lcd.print ("    ");  
  
lcd.setCursor (11, 1);  
  
lcd.print ("NO CH");  
  
}  
  
}  
  
if (tbattery < 11.0)  
  
{  
  
digitalWrite (buzzer, HIGH);  
  
lcd.clear ();  
  
lcd.print ("BATTERY LOW");  
  
lcd.setCursor (0, 1);  
  
lcd.print ("TURNOFF & CHARGE");  
  
do  
  
{  
  
} while (1);  
  
}
```

////////////////////////////////////// ULTRA-SONIC //



●○ REDMI NOTE 8  
○∞ AI QUAD CAMERA

```
lcd.print ("PLACE HAND");  
lcd.setCursor (0, 1);  
lcd.print ("FOR SANITIZER");  
digitalWrite (msg2, HIGH); // welcome place Ur hand near sanitizer  
delay (500);  
digitalWrite(msg2, LOW);  
delay (2000);  
digitalWrite(valve,HIGH);  
delay (sani_timer*1000);  
digitalWrite(valve, LOW);  
lcd.clear ();  
lcd.print ("THANK YOU");  
lcd.setCursor (0, 1);  
lcd.print ("HAVE A NICE DAY");  
digitalWrite (msg3, HIGH); // Thank you, have a nice day  
delay (500);  
digitalWrite (msg3, LOW);  
delay (1500);  
//////////////////////////////////// BATT //////////////////////////////////////  
temperature=0;  
}  
else  
{  
lcd.clear ();  
lcd.print ("HIGH BODY TEMP");  
lcd.setCursor (0, 1);  
lcd.print (temperature, 1);
```

```
lcd.print ((char) 223);  
lcd.print ("C ");  
lcd.print ((temperature*1.8)+32, 1); // C TO F  
lcd.print ((char) 223);  
lcd.print ("F")  
do  
{  
digital Write (msg4, HIGH); // high temperature not allowed into campus  
delay (500);  
digital Write (msg4, LOW);  
delay (5000);  
digital Write (buzzer, HIGH); // high temperature not allowed into campus  
delay(1000);  
digital Write (buzzer, LOW);  
} while (1);  
}  
}  
}
```



## BIBLIOGRAPHY

- [1] Assist. Prof. Giselle Ann Alcoran Alvarez, Marc Brain Garcia, Dave Unabia alvarez, 2020. "Automated Social Distancing Gate with Non-Contact Body Temperature Monitoring using Arduino Uno"
- [2] Asif A. Rahimoon , Mohd Noor Abdullah, Ishkrizat Taib, 2020. "Design of a Contactless Body Temperature Measurement System using Arduino".
- [3] Marlon Gan Rojo, Jolan Baccay Sy, Eunelfa Regie Calihara , Alan Vincent Comendador, Wubishet Degife , Assefa Sisay, 2020. "Non-Contact Temperature Reader with Sanitizer Dispenser (NCTRSD)".
- [4] Juhui Lee, Jin-Young Lee, Sung-Min Cho , Ki-Cheol Yoon, Young Jae Kim , Kwang Gi Kim, 2020. "Design of Automatic Hand Sanitizer System Compatible with Various Containers".
- [5] Rakshith L, Dr. K B Shiva kumar, 2020. "A Novel Automatic Sanitizer Dispenser".
- [6] Akshay Sharma A S , 2020. Review on Automatic Sanitizer Dispensing Machine".
- [7] Enerst Edozie , Wantimba Janat , Zaina Kalyankolo, 2020. "Design and Implementation of a Smart Hand Sanitizer Dispenser with Door Controller using ATMEGA328P".
- [8] M. M. Srihari , 2020. "Self-Activating Sanitizer with Battery Imposed System for Cleansing Hands".
- [9] Jing Zhang , 2017. "Development of a non-Contact Infrared Thermometer".
- [10]Guangli Long, 2016 . "Design of a Non-Contact Infrared Thermometer".

**VISVESVARAYA TECHNOLOGICAL UNIVERSITY**  
BELAGAVI - 590018  
2020 -2021



**A**

**Phase II Project Report**

**on**

**“INDUSTRIAL AUTOMATION BASED ON IoT USING ZIGBEE  
COMMUNICATION PROTOCOL”**

**Submitted in the partial fulfillment of the requirement  
for the VIII Semester Project - 17EEP85 for the award of degree of**

**Bachelor of Engineering**

**in**

**Electrical and Electronics Engineering**

**By**

<b>KAVYA B</b>	<b>1GV17EE006</b>
<b>RAJENDRA PRASAD M</b>	<b>1GV17EE014</b>
<b>VEENA SHIVAPPA PARAMESHWAR</b>	<b>1GV16EE020</b>

**Carried at**

**Dr.T.THIMMAIAH INSTITUTE OF TECHNOLOGY**

**Under the Guidance of  
Mrs. Dhanalakshimi V  
Assoct. Prof.  
Dept. of EEE, Dr.TTIT, K.G.F.**



**Dr.T.Thimmaiah Institute of Technology**

**Oorgaum Post, K.G.F-563120**

**(Approved by AICTE, New Delhi, Affiliated to VTU-Belagavi, Approved by Govt. of  
Karnataka and ISO 21001-2018 Certified)**

# Dr.T.Thimmaiah Institute of Technology



Oorgaum Post, K.G.F-563120  
(Approved by AICTE, New Delhi, Affiliated to VTU-Belagavi,  
Approved by Govt. of Karnataka and ISO 21001-2018 Certified)

## DEPARTMENT OF ELECTRICAL AND ELECTRONICS ENGINEERING

### CERTIFICATE

Certified that the Project Work entitled "**INDUSTRIAL AUTOMATION BASED ON IoT USING ZIGBEE COMMUNICATION PROTOCOL**" is a bonafied work carried out by **KAVYA B-1GV17EE006, RAJENDRA PRASAD M-1GV17EE014, VEENA SHIVAPPA PARAMESHWAR-1GV16EE020**, in the partial fulfillment for the award of degree of Bachelor of Engineering in **Electrical and Electronics Engineering** of the **Visvesvaraya Technological University, Belagavi** during the year 2020-2021. It is certified that all corrections/suggestions indicated for the assessment have been incorporated in the phase 2 project report deposited in the departmental library. The Project report has been approved as it satisfies the academic requirement in respect of **Project Phase II-17EEP85** prescribed for the Bachelor of Engineering Degree.

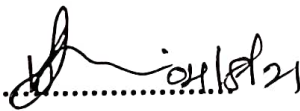
  
.....04/8/21

Signature of Guide  
Mrs. Dhanalakshmi V

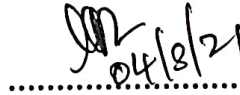
  
.....04/8/21

Signature of HOD  
Dr. N. Lakshmipathy

**Head of the Department**  
Dept. of Electrical Engineering  
**Dr. T. Thimmaiah Institute of Technology,**  
**Oorgaum, K.G.F.-563 120.**

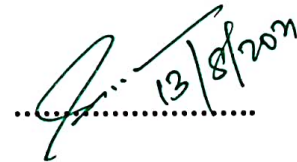
  
.....13/8/2021

Signature of Principal  
Dr. Syed Ariff

PRINCIPAL  
**Dr. T. Thimmaiah Institute of Technology**  
**Oorgaum, K.G.F. - 563 120.**

Name of Examiners

- 1.
2. Jillian Rufus-J

Signature with Date

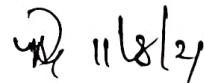
- 1.
2.  11/8/21



## **ABSTRACT**

The current industrial revolution is the industry 4.0. One of its main aims is the replacement of old communication that uses wired links with new communication that is wireless communication. The main reason to move to wireless communication is to improve the mobility, reduce the deployment cost, reduce cable damage and to improve the scalability. To do this, the type of industrial application needs to be taken into consideration. The proposed communication protocol must support low loss rate and must be robust. This is one of the main challenges faced by industrial automation due to interference with other communication devices and reflection with metallic objects in industries. The current industrial revolution is the 4.0 industrial revolution which combines different technologies such as Internet of Things (IOT), robotics, virtual reality and artificial intelligence. The second aim of this paper is to connect devices to IOT so as to improve the accessibility of the industry from anywhere in the world. Apart from communication protocol and IOT, the other services running simultaneously are web browser, email, video or other services. These services are known as Best Effort services. So, this communication protocol not only improves power efficiency of the sensors but also it runs the Best Effort services. The proposed protocol to be used is ZigBee communication protocol along with the IOT service. IOT connect anything on the internet using a specified protocol with sensors, devices, equipment to transfer the information & to communicate among devices intelligently to achieve smart monitoring and administration.

**VISVESVARAYA TECHNOLOGICAL UNIVERSITY**  
BELAGAVI - 590018  
2020 -2021

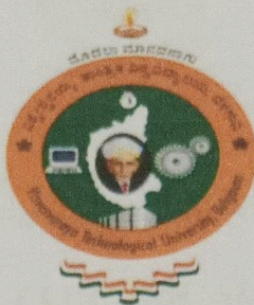

**A**  
**Project Phase Report II**  
**on**  
**“DEVELOPMENT AND OPTIMIZATION OF HYBRID POWER  
GENERATION AND STORAGE TO PROMOTE CLEAN ENERGY”**

**Submitted in the partial fulfillment of the requirement  
for the VIII Semester Project Phase II - 17EEP78 for the award of degree of**

**Bachelor of Engineering**  
**in**  
**Electrical and Electronics Engineering**  
**By**

<b>C NISHAN</b>	<b>1GV17EE004</b>
<b>KISHORE KUMAR N</b>	<b>1GV17EE008</b>
<b>KRUTHIK NL</b>	<b>1GV17EE009</b>
<b>ARUN KUMAR R</b>	<b>1GV18EE400</b>

**Carried at**  
**Dr.T.THIMMAIAH INSTITUTE OF TECHNOLOGY**

**Under the Guidance**  
**of**  
**Mrs. Subhashini S, Asst. Prof,**  
**Dept. of EEE, Dr.TTIT, K.G.F.**



**Dr.T.Thimmaiah Institute of Technology**  
Oorgaum Post, K.G.F-563120  
(Approved by AICTE, New Delhi, Affiliated to VTU-Belagavi,  
Approved by Govt. of Karnataka and ISO 21001-2018 Certified)

Dr.T.Thimmaiah Institute of Technology



Oorgaum Post, K.G.F-563120  
(Approved by AICTE, New Delhi, Affiliated to VTU-Belagavi, Approved  
by Govt. of Karnataka and ISO 21001-2018 Certified)

DEPARTMENT OF ELECTRICAL AND ELECTRONICS  
ENGINEERING

CERTIFICATE

Certified that the Project Work entitled "*Development And Optimization Of Hybrid Power Generation And Storage To Promote Clean Energy*" is a bonafied work carried out by C.Nishan- 1GV17EE004, Kishore Kumar N- 1GV17EE008, Kruthik NL- 1GV17EE009 and Arun Kumar R- 1GV18EE400, in the partial fulfillment for the award of degree of Bachelor of Engineering in **Electrical and Electronics Engineering** of the **Visvesvaraya Technological University**, Belagavi during the year 2020-2021. It is certified that all corrections/suggestions indicated for the assessment have been incorporated in the report deposited in the departmental library. The Project report has been approved as it satisfies the academic requirement in respect of **Project Phase II -17EEP78** prescribed for the Bachelor of Engineering Degree.

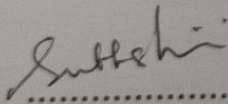
  
.....

Signature of Guide  
Mrs. Subhashini S

Name of Examiners

- 1.
2. Jillian Rufus-J

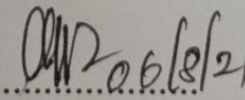
  
.....

Signature of HOD

Dr. N. Lakshmi Pathy  
Head of the Department

Dept. of Electrical Engineering  
Dr. T. Thimmaiah Institute of Technology,  
Oorgaum, K.G.F.-563 120

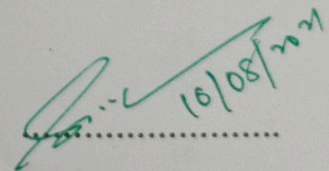
  
.....

Signature of Principal

Dr. Syed Ariff  
PRINCIPAL

Dr. T. Thimmaiah Institute of Technology,  
Oorgaum, K.G.F. - 563 120.

Signature with Date

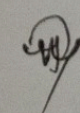
- 1.
2.  11/8/2021

## ABSTRACT

Energy is critical to the economic growth and social development of any country. Indigenous energy resources need to be developed to the optimum level to minimize dependence on imported fuels, subject to resolving economic, environmental and social constraints. This led to an increase in research and development as well as investments in the renewable energy industry in search of ways to meet the energy demand and to reduce the dependency on fossil fuels. Wind, hydro and solar energy are becoming popular owing to the abundance, availability and ease of harnessing the energy for electrical power generation.

Stand-alone power generation systems make use of solar PV and turbines to produce and store the energy for future use. Solar electricity has regulations that it could not produce power within the night and in the cloudy season so we want to triumph over this drawback we will use each wind, solar and hydro together so that any individual of source fails every other supply will maintain generating the electricity and in accurate weather situation. It is a hardware proposed design of a compact stand-alone hybrid power generation system using wind-hydro-solar resources. This system can be implemented in industries/houses where the wind and solar energies are obtained by turbine and PV-Cells , during the rain the water is allowed to flow through a mini-turbine which in-turn produce energy during the rain fall. Finally total energies will be acquired simultaneously for charging the batteries and is utilized for satisfying the electrical demands of domestic and rural areas. Uninterrupted power can be supplied in industries and factories using an inverter.